

REVISION HISTORY			
REV	DESCRIPTION	DATE	BY
A	RELEASED	8/29/2005	RM

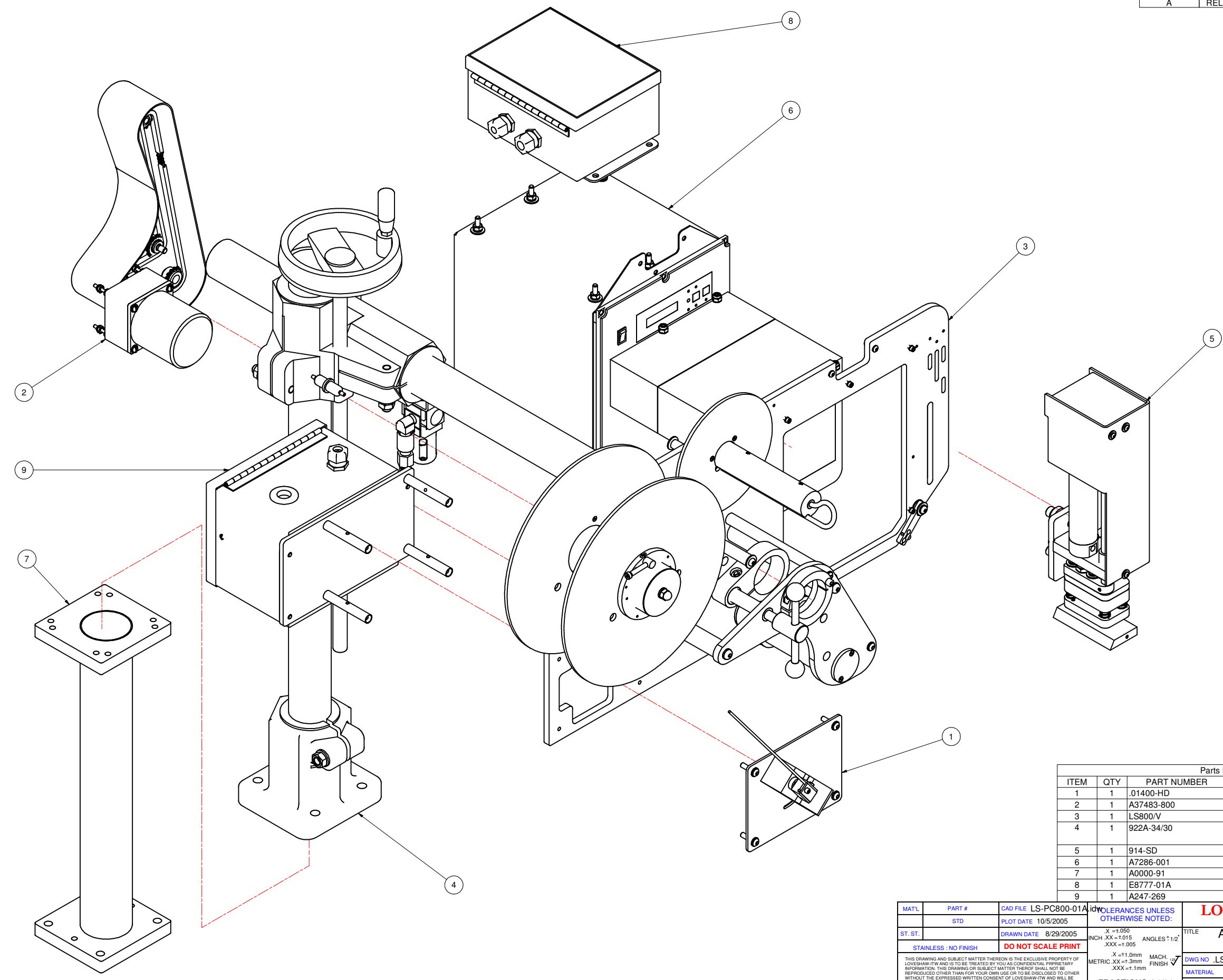

Parts List			
ITEM	QTY	PART NUMBER	DESCRIPTION
1	1	.01400-HD	LOW LABEL SWITCH, HEAVY DUTY
2	1	A37483-800	DRIVE PACKAGE - LS-800
3	1	LS800/V	BASE ASSEMBLY
4	1	922A-34/30	DELTA MOUNT 34" W/30" CROSSTUBE
5	1	914-SD	TAMP APPLICATOR ASSEMBLY
6	1	A7286-001	PRINTER ASSEMBLY
7	1	A0000-91	PEDESTAL ASSY 20 INCH
8	1	E8777-01A	ELECTRICAL JUNCTION BOX
9	1	A247-269	AIR BOX ASSEMBLY

MATL	PART #	CAD FILE LS-PC800-01A	TOLERANCES UNLESS OTHERWISE NOTED:	LOVESHAW an <i>itw</i> Company RT. 296, SOUTH CANAAN, PA. ATHS PRINT AND APPLY SYSTEM
ST. ST.	STD	PLOT DATE 10/5/2005	X = ±.050 INCH XX = ±.015 ANGLS ±1/2° .XXX = ±.005 X = ±1.0mm MACH. ✓ METRIC XX = ±.3mm .XXX = ±.1mm	
STAINLESS - NO FINISH		DO NOT SCALE PRINT		DWG NO .LS-PC800-01A SCALE 3/8:1 MATERIAL RICHM DRAWN RICHM APPROVED
<small>THIS DRAWING AND SUBJECT MATTER THEREON IS THE EXCLUSIVE PROPERTY OF LOVESHAW ITW AND IS TO BE TREATED BY YOU AS CONFIDENTIAL PROPRIETARY INFORMATION. THIS DRAWING OR SUBJECT MATTER THEREOF SHALL NOT BE REPRODUCED OTHER THAN FOR YOUR OWN USE OR TO BE DISCLOSED TO OTHER WITHOUT THE EXPRESSED WRITTEN CONSENT OF LOVESHAW ITW AND WILL BE RETURNED TO LOVESHAW ITW UPON REQUEST.</small>				TITLE SCALE 3/8:1 CHECKED APPROVED