

REVISION HISTORY			
REV	DESCRIPTION	DATE	BY
A	RELEASED	10/3/2005	RM

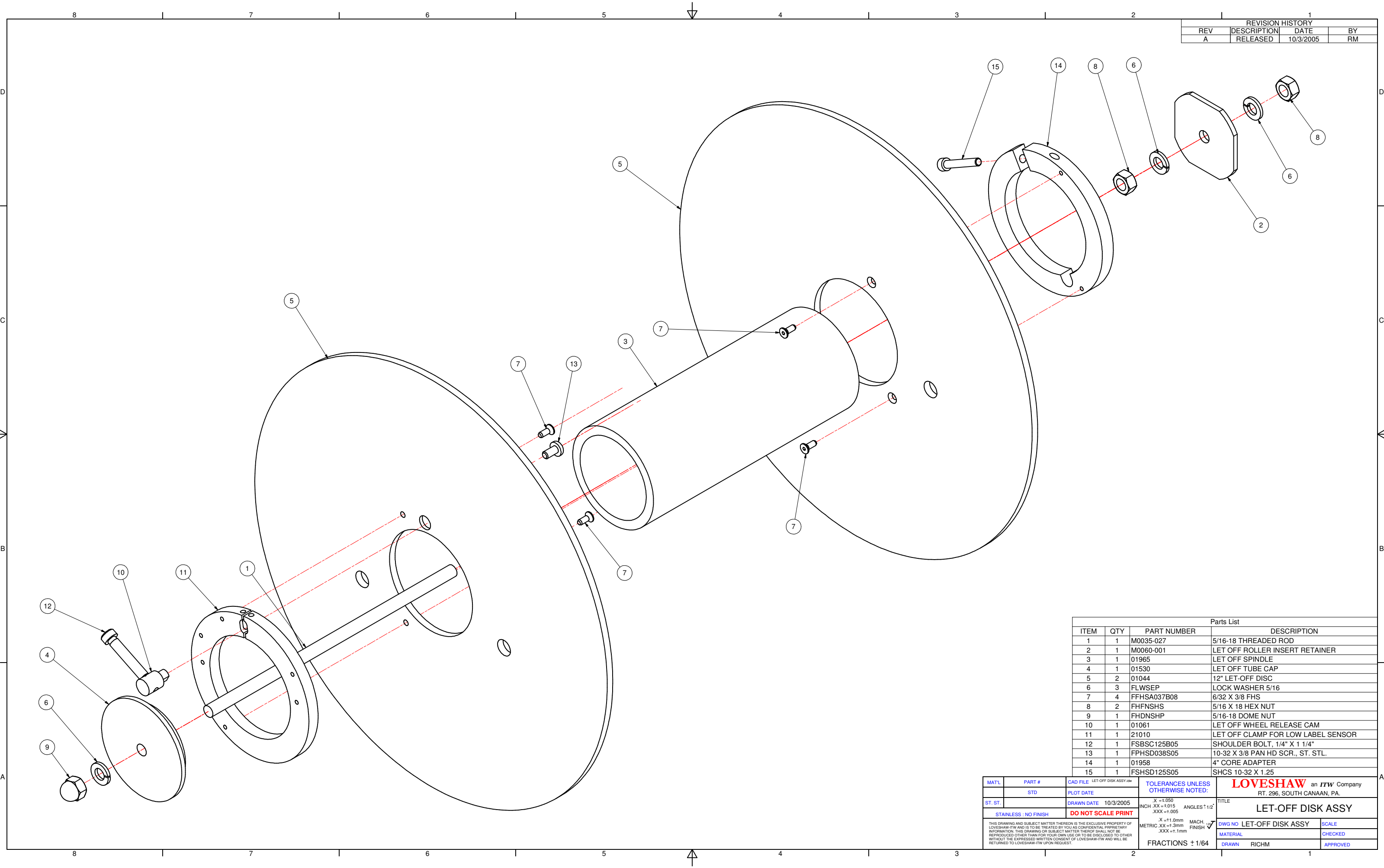

Parts List			
ITEM	QTY	PART NUMBER	DESCRIPTION
1	1	M0035-027	5/16-18 THREADED ROD
2	1	M0060-001	LET OFF ROLLER INSERT RETAINER
3	1	01965	LET OFF SPINDLE
4	1	01530	LET OFF TUBE CAP
5	2	01044	12" LET-OFF DISC
6	3	FLWSEP	LOCK WASHER 5/16
7	4	FFHSA037B08	6/32 X 3/8 FHS
8	2	FHFNSHS	5/16 X 18 HEX NUT
9	1	FHDNSHP	5/16-18 DOME NUT
10	1	01061	LET OFF WHEEL RELEASE CAM
11	1	21010	LET OFF CLAMP FOR LOW LABEL SENSOR
12	1	FSBSC125B05	SHOULDER BOLT, 1/4" X 1 1/4"
13	1	FPHSD038S05	10-32 X 3/8 PAN HD SCR., ST. STL.
14	1	01958	4" CORE ADAPTER
15	1	FSHSD125S05	SHCS 10-32 X 1.25

MATL	PART #	CAD FILE	LET-OFF DISK ASSY.dwg	TOLERANCES UNLESS OTHERWISE NOTED:	LOVESHAW an <i>ITW</i> Company RT. 296, SOUTH CANAAN, PA.
ST. ST.	STD	PLOT DATE	10/3/2005	X = ±1.050 INCH XX = ±0.015 ANGLS ±1/2° .XXX = ±1.005 X = ±1.0mm MACH. ✓ METRIC XX = ±1.3mm FINISH ✓ .XXX = ±1.1mm	
STAINLESS - NO FINISH		DO NOT SCALE PRINT		TITLE	
<small>THIS DRAWING AND SUBJECT MATTER THEREON IS THE EXCLUSIVE PROPERTY OF LOVESHAW ITW AND IS TO BE TREATED BY YOU AS CONFIDENTIAL PROPRIETARY INFORMATION. THIS DRAWING OR SUBJECT MATTER THEREOF SHALL NOT BE REPRODUCED OTHER THAN FOR YOUR OWN USE OR TO BE DISCLOSED TO OTHER WITHOUT THE EXPRESSED WRITTEN CONSENT OF LOVESHAW ITW AND WILL BE RETURNED TO LOVESHAW ITW UPON REQUEST.</small>				DWG NO LET-OFF DISK ASSY SCALE MATERIAL CHECKED DRAWN RICHM APPROVED	
FRACTIONS ±1/64					