

# LITTLE DAVID

*OWNERS MANUAL*



## CAC50MI

THE LOVESHAW CORPORATION  
2206 EASTON TURNPIKE  
SOUTH CANAAN, PA 18459

TEL: (570) 937-4921  
FAX: (570) 937-4370

LOVESHAW - EUROPE  
UNIT 9, BRUNEL GATE  
W. PORTWAY INDUSTRIAL ESTATE  
ANDOVER, HAMPSHIRE SP103SL  
ENGLAND  
44-264-3575-11

## **Part and Instruction Manual**

**Loveshaw Pressure Sensitive Tape Cartridge**

**CAC50 – 2” wide tape**

**CAC51 – 3” wide tape**

## **Theory of Operation:**

**Pressure sensitive tape is applied to the corrugated box as it passes by the cartridge. The box will contact the front arm roller which has pressure sensitive tape adhesive side facing outward towards the oncoming box. The front leading side of the box will contact the front roller arm and the tape will adhere to the box. As the box continues to move forward the front roller arm and knife arm will be rotated into the frame of the cartridge. The amount of force exerted on the box as tape is being applied is adjustable by changing the position of the main spring. The front arm initial application force can be set to accommodate the strength of the box as well as the sturdiness of the contents in the box.**

**As the front arm application roller transitions from the leading panel of the box to the top major flaps, the knife arm contacts the major flaps. The knife guard is linked to the front roller arm and retracts to clear the knife blade. As the knife arm rotates into the cartridge the knife activation spring compresses, generating cut force.**

**As the box proceeds pass the cartridge the front arm roller will no longer contact the major flaps of the box, but the rear wipe roller will still contact the major flaps. Eventually as the box travels the knife arm will completely stop contacting the major flaps of the box. This will allow the knife arm to travel back towards its home position allowing the knife blade to puncture and cut through the tape. As the box continues move the rear wipe arm roller will no longer contact the major flaps of the box. This will allow the wipe arm roller to spring out of the cartridge and contact the rear tab length of tape and press against the trailing panel of the box.**

**The box travelling pass the cartridge is the vehicle which pulls the tape through the cartridge. The cartridge is design to run most pressure sensitive tapes with no required adjustments. However in some cases it may be necessary to adjust tape tensions. The cartridge will operate at speeds up to 90 feet/minute.**

## **Important Safety Notices:**

**Before installing operating or servicing the tape cartridges read carefully and understand the following precautions:**

- **Never service the tape cartridges when installed in an operating machine.**
- **Use lock out / tag out protocols before installing or removing cartridges from machinery.**
- **Do not bypass or remove safety guard on knife blade.**
- **Observe caution when near tape cartridge knife. The knife blade is protected by a locking cover which is held closed by the link bar.**
- **Never make any adjustments to the tape cartridges when installed in an operating machine.**

## Tape Threading:

The first step is to place the tape roll, on the cartridge tape core. Make sure that the tape roll is fully bottomed against the face of the core. The first step is to place the tape roll, on the cartridge tape core. Make sure that the tape roll is fully bottomed against the face of the core. Spring clips on the side of the tape core makes up for inner diameter core fluctuations of the tape roll.

Tape roll must be placed on tape core with adhesive side of tape facing to the right. Refer to figure 2 and 3 for proper orientation.

Figure 1

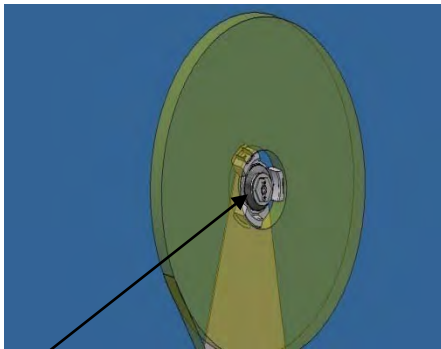

Tape  
core

Figure 2

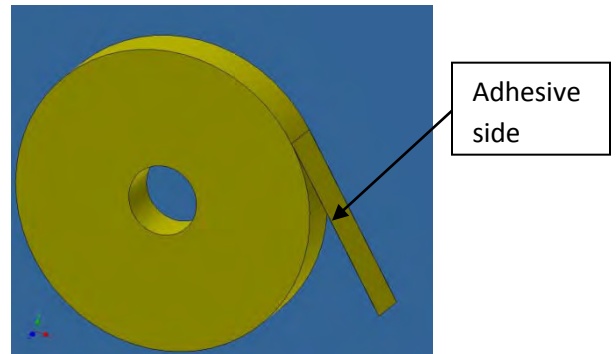

Adhesive  
side

Continue threading the tape behind the black knurled tension roller. The adhesive side of the tape contacts the knurled roller. The tape is then threaded over the aluminum idler roller with the non adhesive side of the tape contacting it. The tape is then fed through the horse shoe bracket roller section of the cartridge. The tape is threaded behind the two small diameter black knurled rollers (upper and lower) and in front of the nylon idler roller. The adhesive side

of the tape contacts both small knurled rollers. The tape is then threaded between the finger plate and the tape guide fingers. This completes the threading Refer to figure 3 and 4.

Figure 3

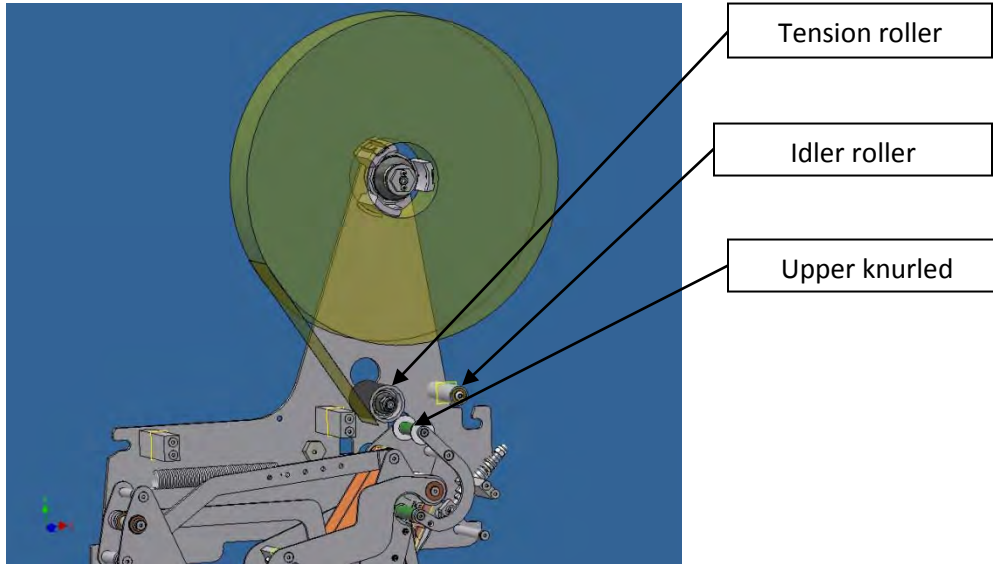
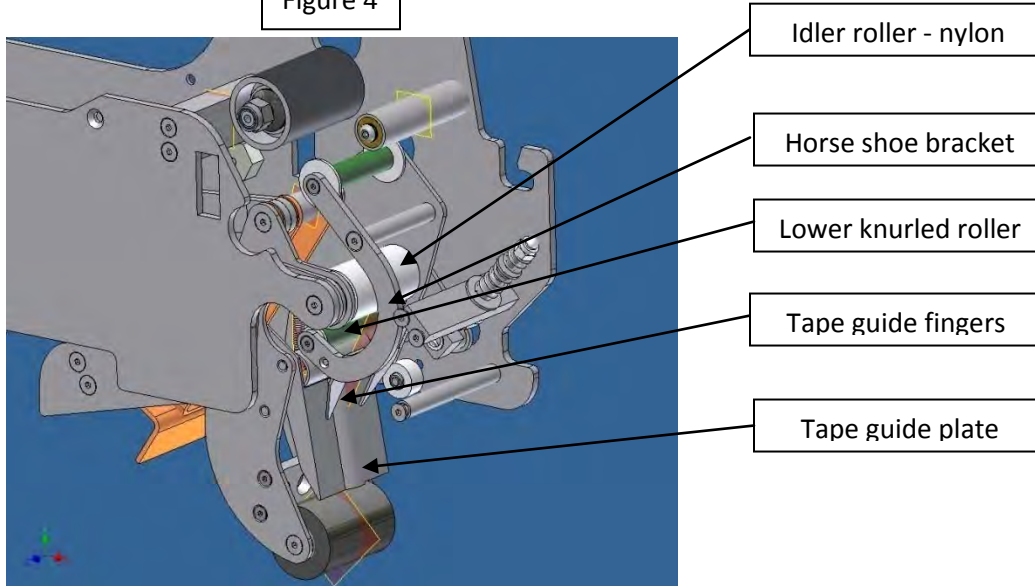

Figure 4



## Adjustments:

- **Aligning tape :**

Aligning tape side to side within the cartridge frame is done by changing the position of the tape core. This is done by first loosening the tape core locking screw with a 3mm hex key. Turn the tape core locking screw counter clockwise allowing for the desired amount of adjustment to be made. Now turn the tape core height adjusting nut until the desired result is obtained. By turning the tape core height adjusting nut clockwise the tape core height position will decrease moving the tape closer to the mill stand side of the cartridge. By turning the tape core height adjusting nut counter clockwise the tape core height position will increase. This will make the tape track further away from the mill stand. After each adjustment always tighten the tape core locking screw. Failure to do so will allow the tape core position to change as tape is being pulled off the tape roll. Refer to figure 5

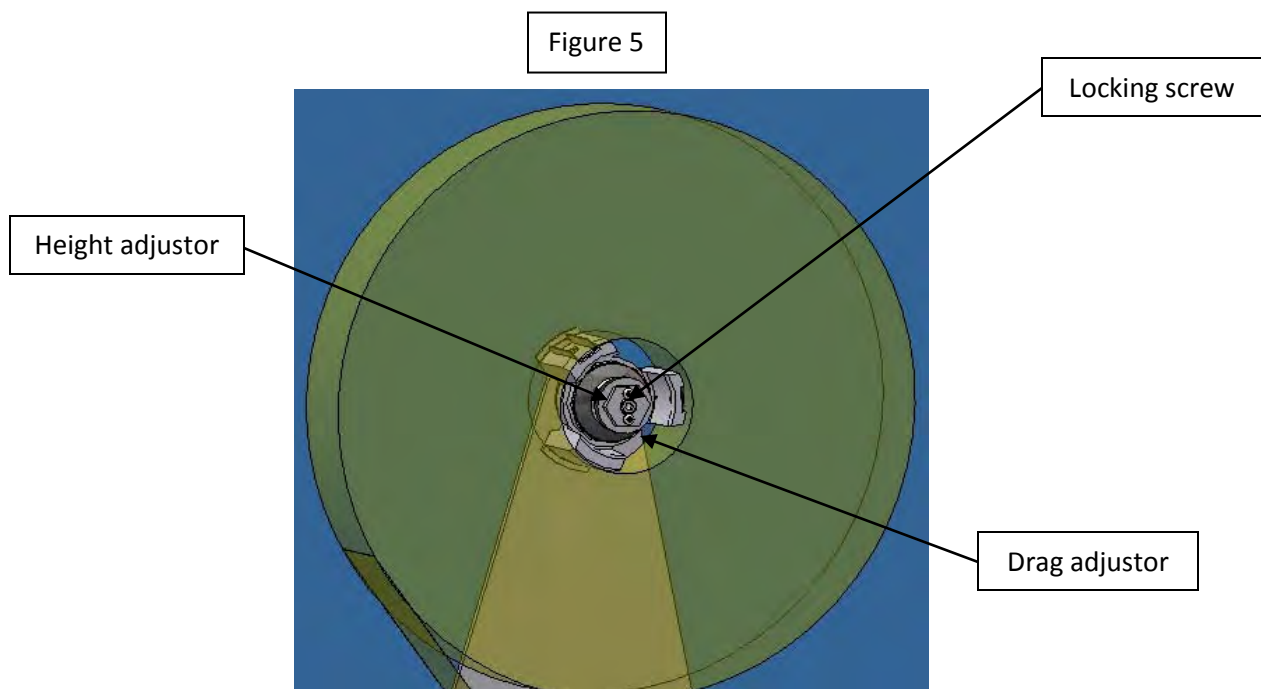

- **Setting tape core drag:**

The tape core drag setting is factory set to not allow a full roll of tape to free wheel as tape is being pulled off it. Different types of tapes adhesives require different pull off force. It is crucial for proper operation that the tape roll is not allowed to free wheel or roll up on its self. To increase tape drag turn the knurled adjustor clockwise and to decrease turn it counter clockwise. Refer to figure 5.

- **Setting the knurled tension roller:**

The knurled tension roller is factory set to its optimal setting for a thin milled tape. Not enough tension results in poor tape cutting; adversely too much tension results in tape breakage or the tape snapping back when the tape is cut. Rotating the tension roller adjustor nut clockwise increases tension and rotating it counter clockwise decreases tension. Refer to figure 6.

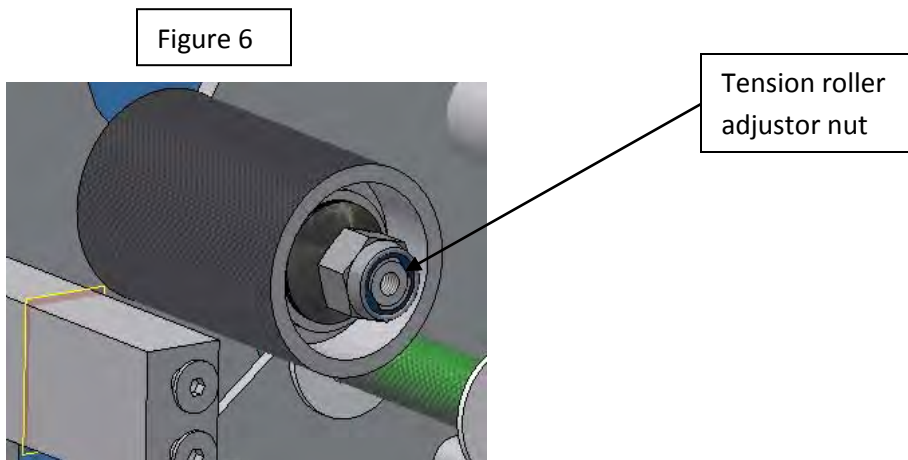

- **Setting main spring tension:**

Setting the main spring tension is done by moving the end of the spring to a different preset position. The main spring tension is factory set to a mid position. The spring is set from lightest to stoutest dependant on the



strength of the corrugated box and the fill of the contents. Void filled, weak corrugated boxes would be set to the lightest setting while strong corrugated box with overfill would process better with the main spring set stronger. The main spring only effects the application and wipe rollers. Refer to figure 7.

Figure 7

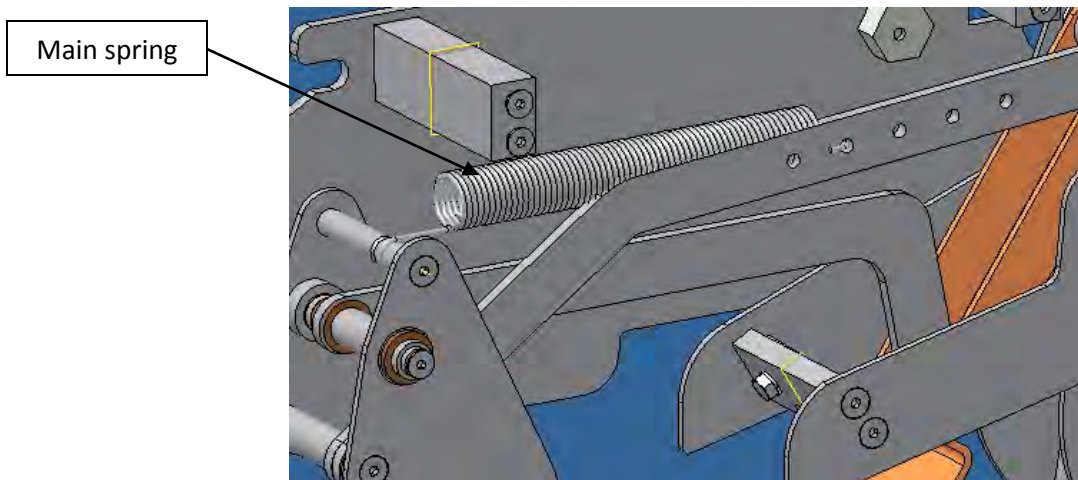

- **Setting knife cut force spring:**

The knife cut force spring is a compression type spring. The spring is used to articulate the knife arm when the box release it. The knife springs out of the cartridge and through the tape. The amount of force that the knife arm cuts with is controlled by the compression spring. By turning the adjust nut clockwise the amount of spring force is increased. By turning the adjustor nut counter clockwise the force is decreased. Refer to figure 8.

Figure 8

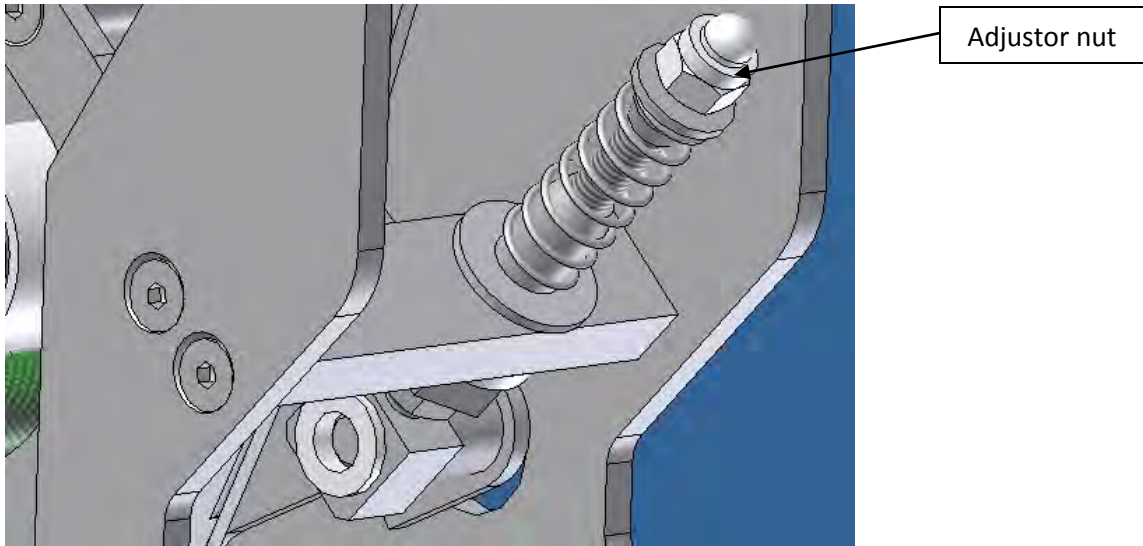

- **Front arm stopper adjustment:**

The front arm stop adjustment is factory set to insure that the front arm roller stays in contact with major flaps of the box. This allows for a tight tape seal across the horizontal length of the box. The adjuster does not need to be adjusted for normal applications. In some cases it may be necessary to adjust the stop depending on the type of machine that the cartridge is being used in. If the cartridge is placed in a machine and the tape is not being applied to the major flaps with enough pressure an adjustment will be necessary. This will be evident by inspecting the box as it exits the machine. Normal symptoms include the tape bridging across the major flaps, or the tape bunching up on the major flaps after the tape was cut. Refer to figure 9.

Figure 9

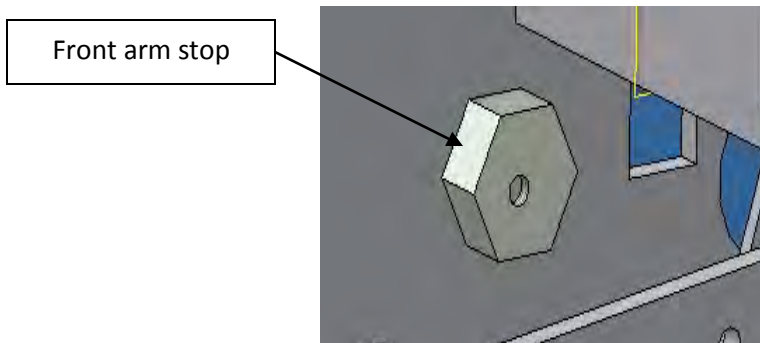

## Maintenance:

- **Application / Wipe roller replacement:**

Roller replacement requires the use of a 3mm hex key wrench and a propane torch. The screws must first be heated in order to break the loctite screw adhesive loose. The application roller has a one way clutch roller in it and the rear wipe roller does not have the clutch roller. It is important to check to rotation of the new application roller when installing it. The roller must turn in the direction of box travel. Refer to figure 10.

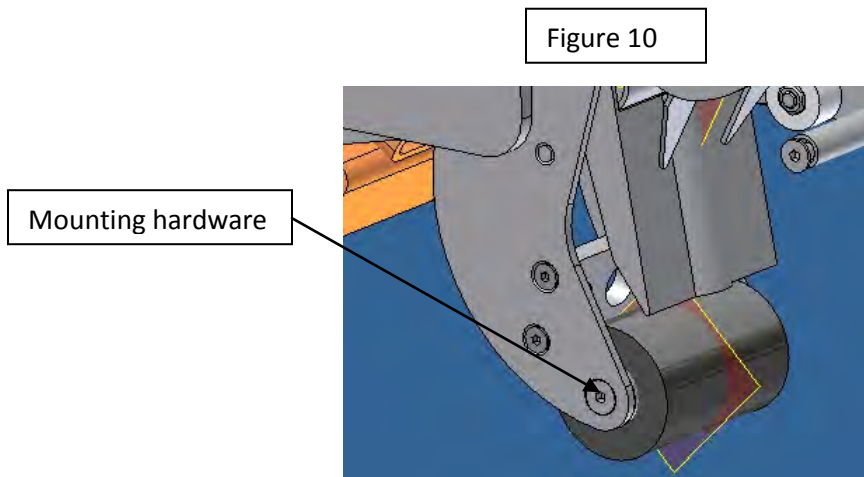

- **Knife blade replacement:**

Knife blade replacement requires either an 8mm box or socket wrench. By loosening the two holding screws the blade can be slid out and the new blade slid in. There is locating pin that insures proper orientation. Take caution not to set the blade too high in the holder so that the knife guard doesn't collide with it. Refer to figure 11.

**Warning:** – Use extreme care when working near the knife blade. The blade is extremely sharp. If care is not taken severe personal injury can occur.

Figure 11

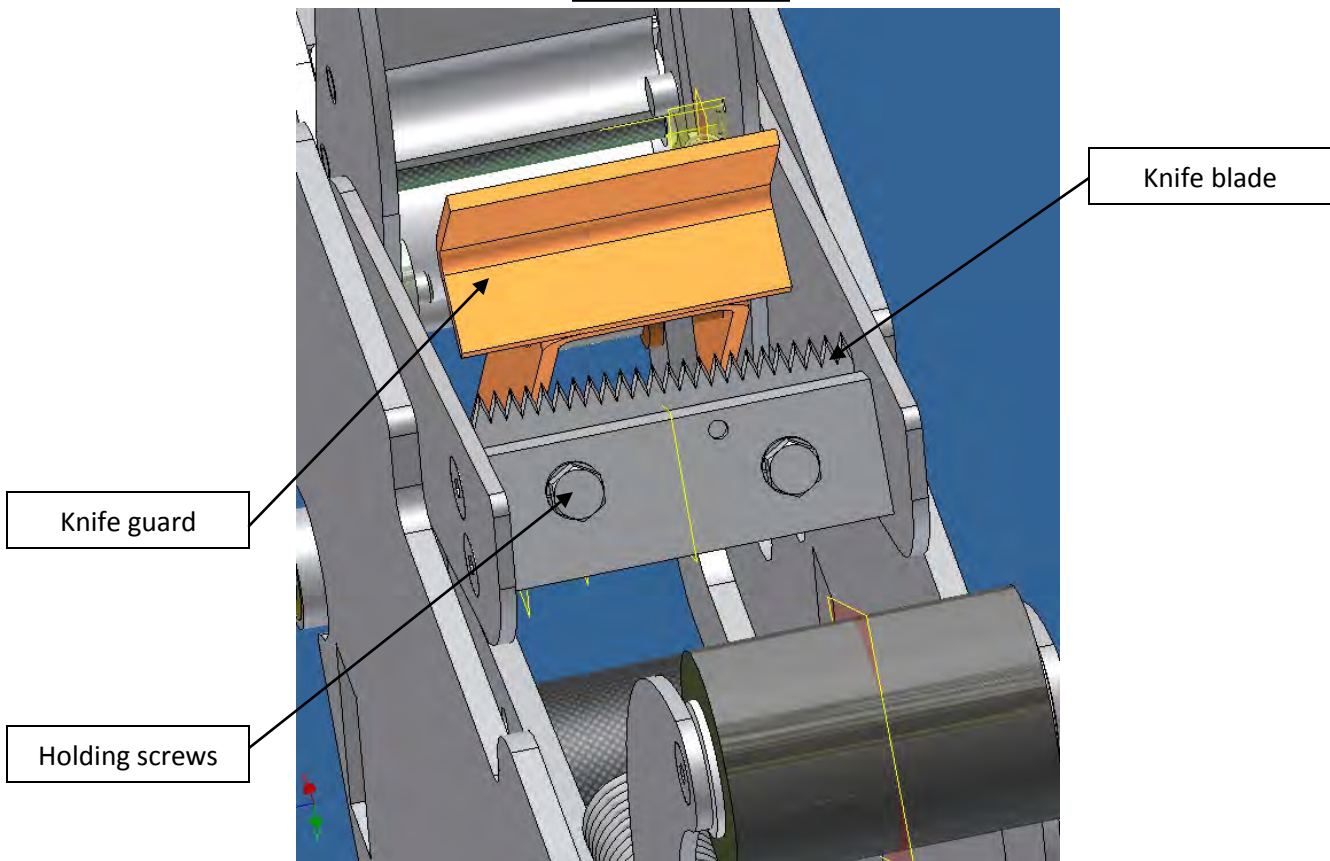

## Troubleshooting:

<b>Problem</b>	<b>Cause</b>	<b>Corrective Action</b>
The tape is not cut, or the cut is not clean.	<p>Knife blade is damaged or needs to be cleaned.</p> <p>Tape tension needs to be increased.</p> <p>Tape is not centered on rollers.</p> <p>Knife spring missing or worn.</p>	<p>Replace knife blade.</p> <p>Increase drag on knurled tension roller.</p> <p>Adjust tape core height.</p> <p>Replace spring.</p>
Front tab length too long.	<p>Cartridge threaded incorrectly.</p> <p>Tape tension needs to be increased.</p> <p>Tape is not centered on rollers.</p>	<p>Check threading diagram on cartridge frame.</p> <p>Increase drag on knurled tension roller.</p> <p>Adjust tape core height.</p>
Rear tab not fully wiped down	<p>Rear tab length too long.</p> <p>Main spring tension too weak.</p> <p>Main spring broken or worn.</p>	<p>Increase drag on knurled tension roller.</p> <p>Adjust main spring tension.</p> <p>Replace main tension spring.</p>
Rear tab too long.	<p>Knife spring worn.</p> <p>Not enough tape tension</p>	<p>Replace knife spring.</p> <p>Increase drag on knurled tension roller.</p>

# TAPE THREADING DIAGRAM

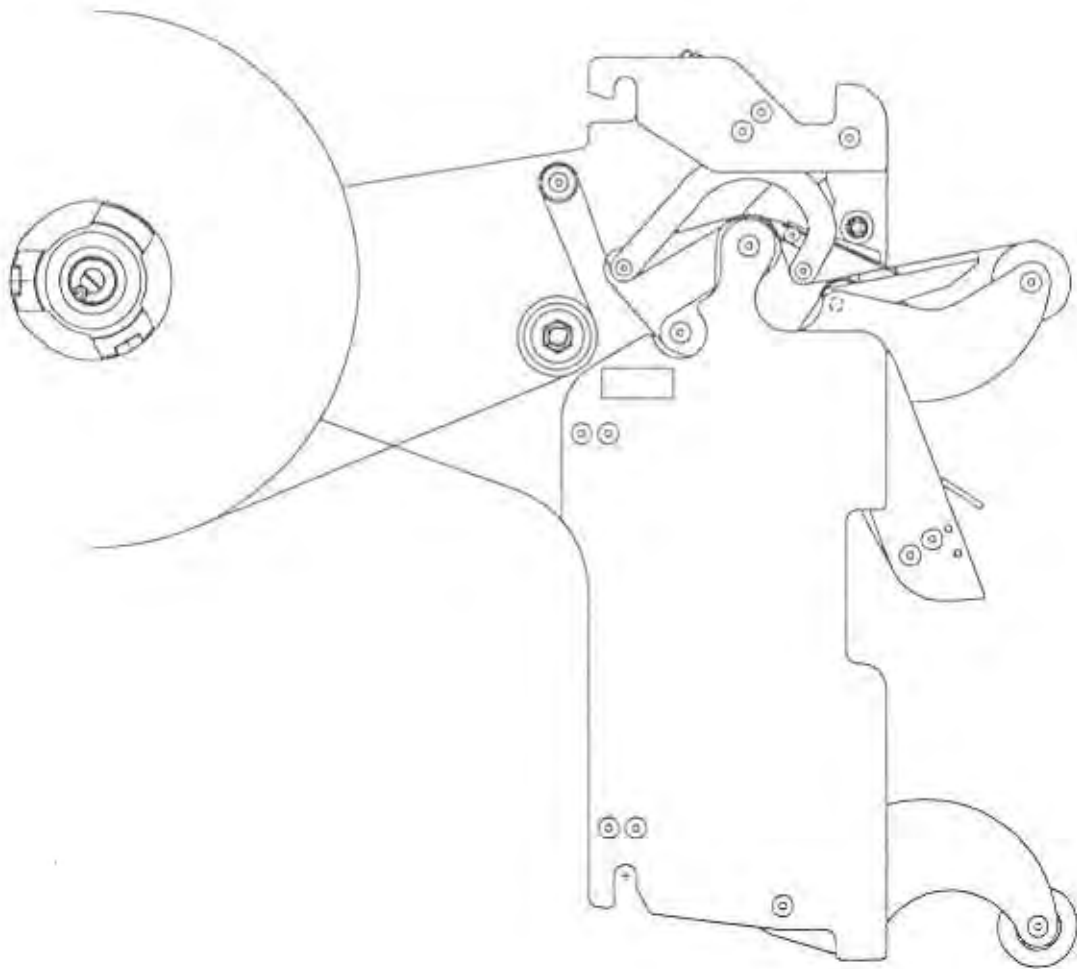

# CARTRIDGE OVERVIEW

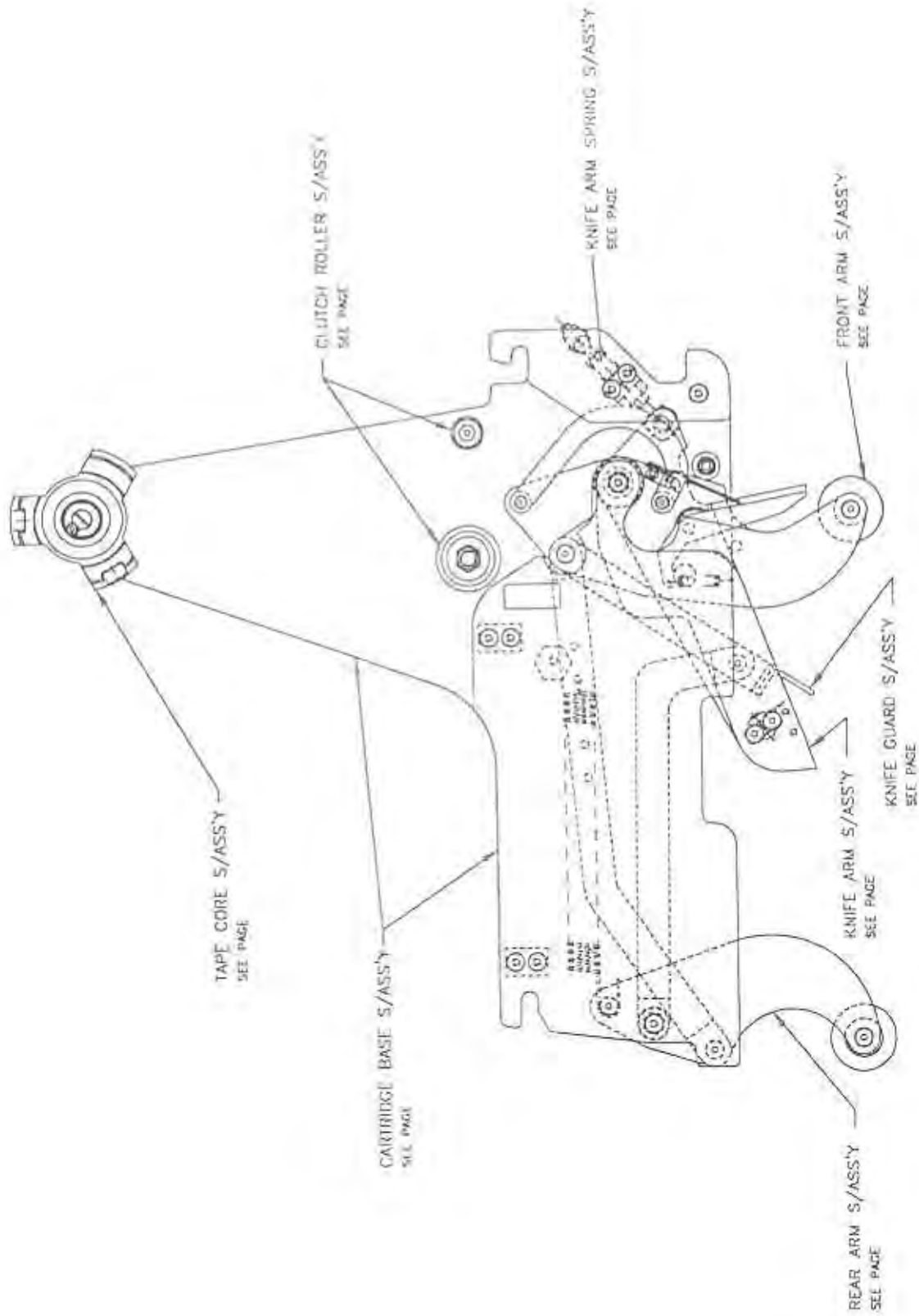

# CARTRIDGE BASE ASSEMBLY

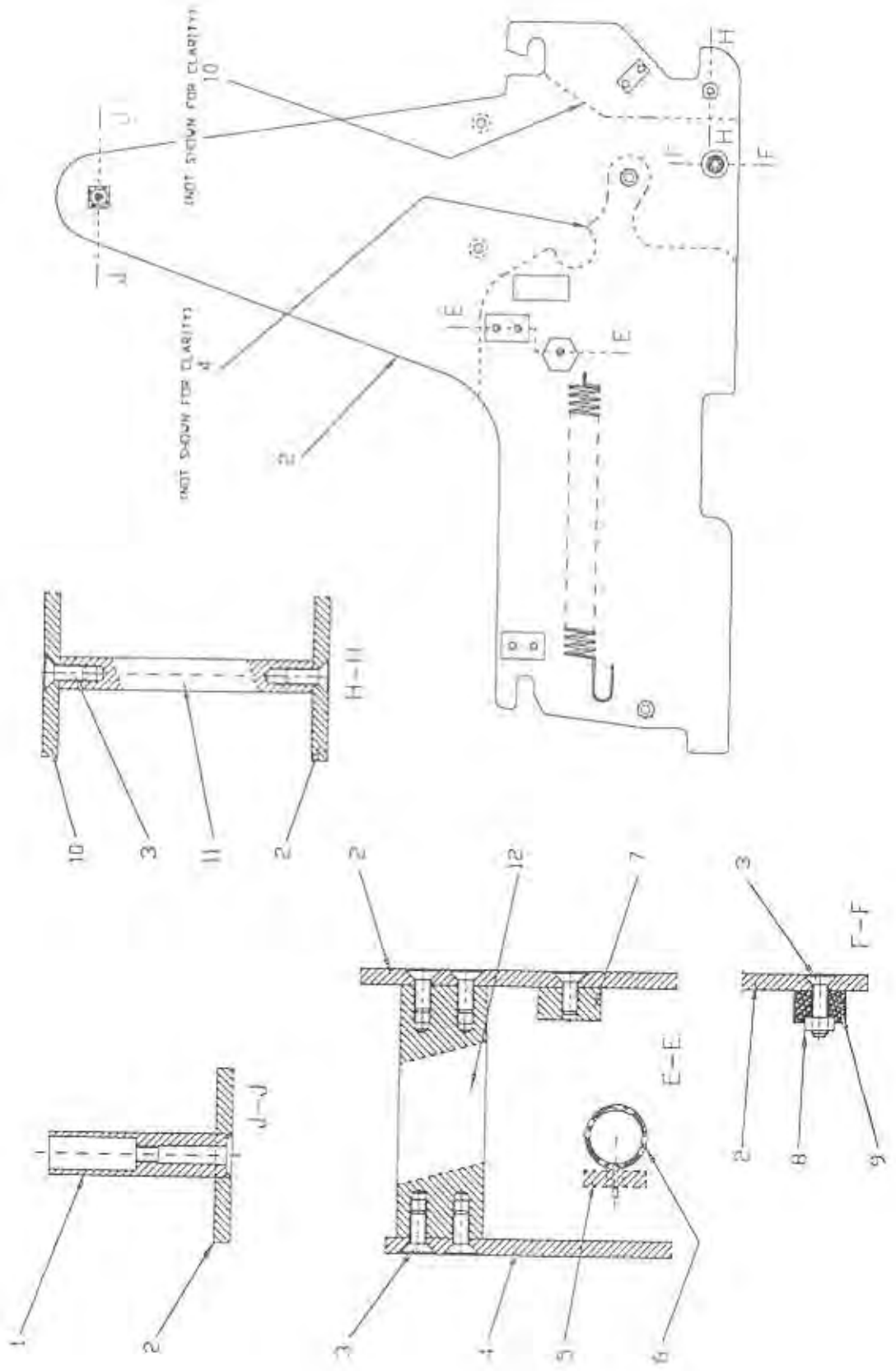



## CARTRIDGE BASE ASSEMBLY

KEY	PART NUMBER	DESCRIPTION	QTY
1	CAC50-047-3	SLEEVE	1
2	CAC50MI-102-6	FRAME - MAIN	1
3	-----	M5 X FH-SCREW	23
4	CAC50MI-019-5	FRAME - TOP	1
5	CAC50-003-4	CONNECTING LINK - ARMS	1
6	PSC501101-4	CARTRIDGE MAIN SPRING	1
7	PSC301117-3	STOP ROLLER ARM	2
8	-----	M5 HEX NUT	1
9	CAC50-050-3	STOPPER - FRONT ARM	2
10	CAC50-012MI-3	FRAME - TOP EXCESS	1
11	PSC321025B-4	SHAFT - CARTRIDGE PLATE	1
12	CAC50-015-3	BLOCK - FRAME	2

# FRONT ARM ASSEMBLY

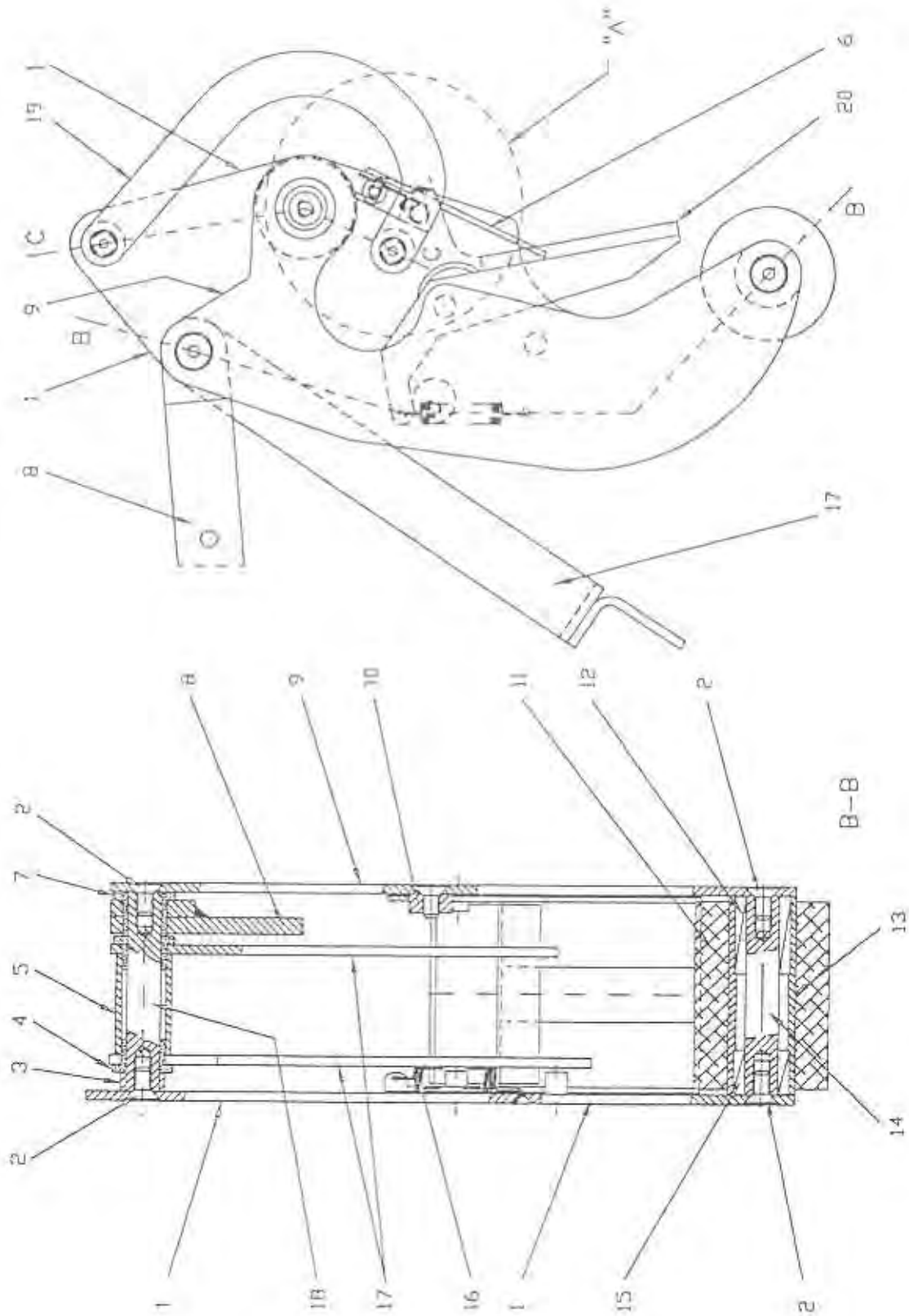

## FRONT ARM ASSEMBLY

KEY	PART NUMBER	DESCRIPTION	QTY
1	CAC50MI-005-4	FRONT ARM - MAIN	1
2	-----	M5 X 10 FH SCREW	3
3	CAC50-040-3	SPACER - CONN. ARM	1
4	50186-039	BRONZE FLANGE BUSHING 3/8 X 1/2 X 3/8	2
5	PSC301110-3	SPACER 1/2 ID X 1 1/8 LONG	1
6	PSC311003MI-4	TAPE HOLD DOWN PLATE	1
7	50186-007	BRONZE FLANGE BUSHING 3/8 X 1/2 X 1/2	1
8	CAC50-003-4	CONNECTING LINK - ARMS	1
9	CAC50MI-006-4	FRONT ARM - TOP	2
10	PSC139-3	STOP - TAPE GUIDE PLATE	1
11	PSC12/1-3	WIPE ROLLER	2
12	J205-PS	TORRINGTON BEARING	1
13	CAC50-039-3	SLEEVE - NEEDLE BEARING	1
14	CAC50-037-3	SHAFT - FRONT ROLLER	1
15	J206-PS	TORRINGTON BEARING	1
16	PSC26-3	SPRING EXT. - GUIDE PLATE	1
17	CAC50-011MI-4	KNIFE GUARD	1
18	CAC50-036-3	SHAFT - WIPE ROLLER	3
19	JBW1014MI-3	HORSE SHOE	1
20	CAC50MI-018-4	TAPE GUIDE PLATE	1

# FRONT ARM ASSEMBLY 2

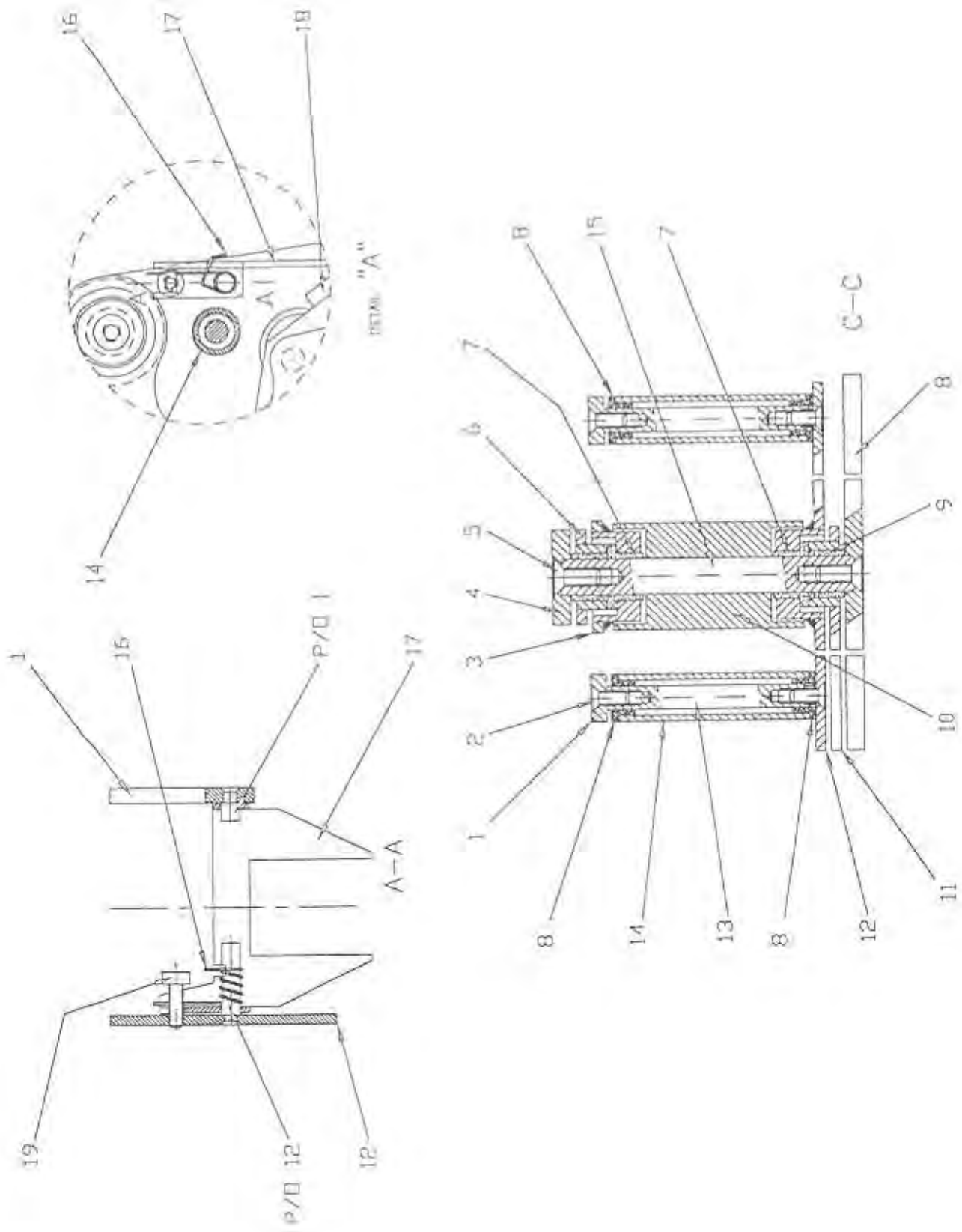

## FRONT ARM ASSEMBLY 2

KEY	PART NUMBER	DESCRIPTION	QTY
1	JBW1014MI-3	HORSE SHOE	1
2	-----	M4 X FH SCREW	3
3	CAC50MI-006-4	FRONT ARM - TOP	2
4	CAC50MI-019-5	FRAME - TOP	1
5	-----	M5 X FH SCREW	23
6	CAC50MI-010-4	KNIFE ARM - TOP	1
7	50186-039	BRONZE FLANGE BUSHING 3/8 X 1/2 X 3/8	4
8	PSC599	NYLON BUSHING	5
9	50185-049	BRONZE FLANGE BUSHING 3/8 X 1/2 X 3/8	2
10	CAC50-046-3	CENTER ROLLER - 1.12 DIA.	2
11	CAC50MI-009-4	KNIFE ARM - MAIN	1
12	CAC50MI-005-4	FRONT ARM - MAIN	1
13	CAC50-044-3	SHAFT - 1/2 DIA. KNURL. ROLLER	2
14	CAC50-045-3	KNURLED ROLLER - 1/2 DIA.	2
15	CAC50-034-3	SHAFT - PIVOT ARM	2
16	PSC321022MI-4	FINGER PLATE SPRING	1
17	PSC311003MI-4	TAPE HOLD DOWN PLATE	1
18	CAC50MI-018-4	TAPE GUIDE PLATE	1
19	-----	M4 X 15 ROUND HD. SCREW	1

# REAR ARM ASSEMBLY

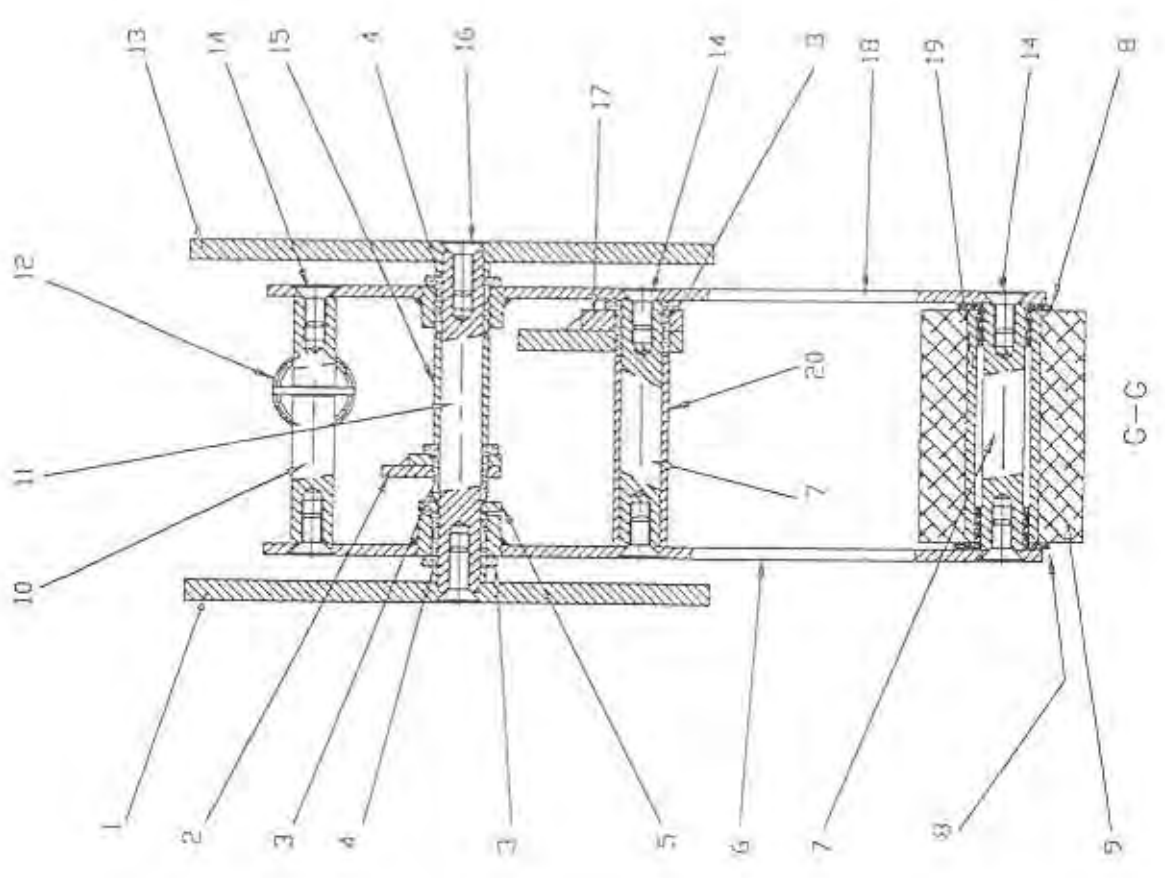
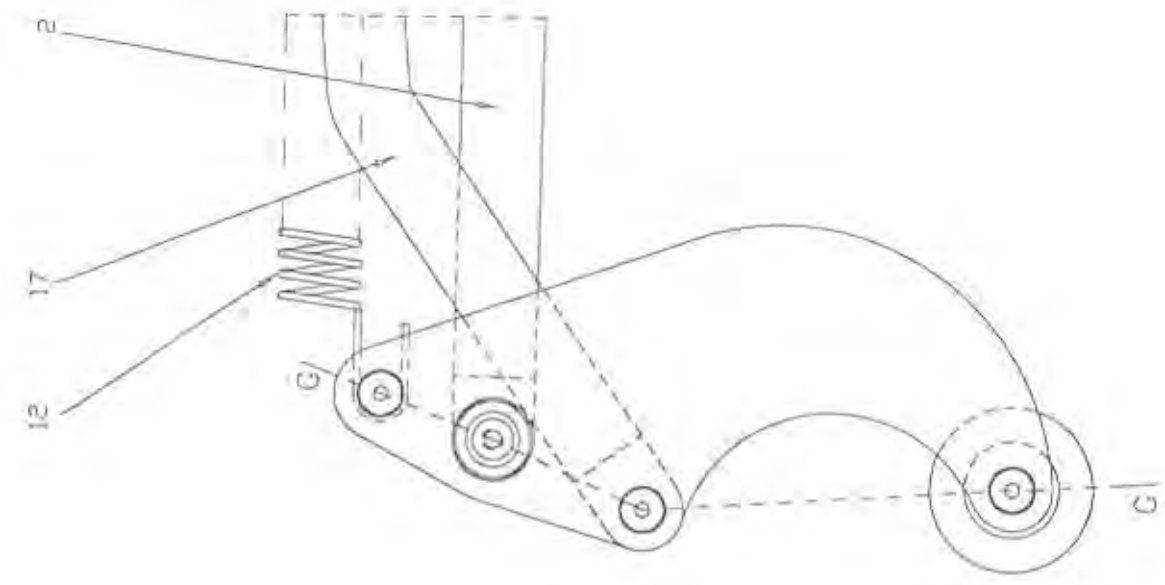

## REAR ARM ASSEMBLY

KEY	PART NUMBER	DESCRIPTION	QTY
1	CAC50MI-102-6	FRAME - MAIN	1
2	CAC50-004-4	CONN. LINK - KNIFE GUARD	1
3	50186-007	BRONZE FLANGE BUSHING 3/8 X 1/2 X 1/2	6
4	CAC50-049-3	SPACER - REAR ARM PIVOT	2
5	-----	3/8 DIA. NOM SAE WASHER	1
6	CAC50-007-4	REAR ARM - TOP	1
7	CAC50-036-3	SHAFT - WIPE ROLLER	3
8	PSC12/3-3	BUSHING - WIPE ROLLER	2
9	PSC12/1-3	WIPE ROLLER	2
10	CAC50-022-3	STUD - REAR ARM SPRING	1
11	CAC50-034-3	SHAFT - PIVOT ARM	2
12	PSC501101-4	CARTRIDGE MAIN SPRING	1
13	CAC50MI-019-5	FRAME - TOP	1
14	-----	M5 X 10 FH SCREW	13
15	CAC50-043-3	SPACER - REAR PIVOT ARM	1
16	-----	M5 X 12 FH SCREW	23
17	CAC50-003-4	CONNECTING LINK - ARMS	1
18	CAC50-008-4	REAR ARM - LEFT	1
19	PSC12/2-3	SLEEVE - WIPE ROLLER	1
20	CAC50-042-3	SPACER - REAR CONN. ARM	1

# KNIFE ARM ASSEMBLY

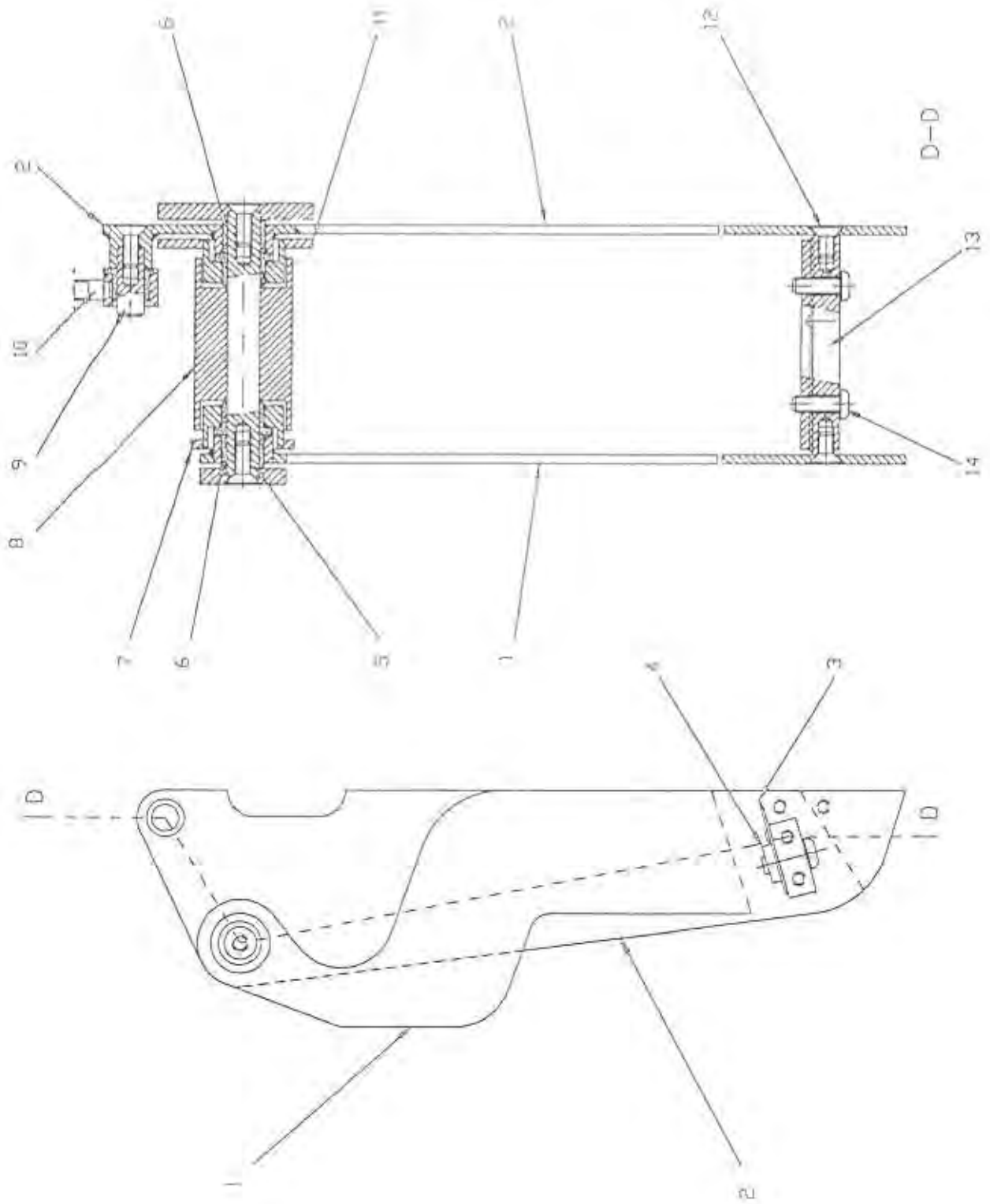



## KNIFE ARM ASSEMBLY

KEY	PART NUMBER	DESCRIPTION	QTY
1	CAC50MI-010-4	KNIFE ARM - TOP	1
2	CAC50MI-009-4	KNIFE ARM - MAIN	1
3	PSC11B-4	KNIFE	1
4	PSC9-3	PLATE - KNIFE	1
5	CAC50-034-3	SHAFT - PIVOT ARM	2
6	50185-049	BRONZE FLANGE BUSHING 3/8 X 1/2 X 3/8	2
7	CAC50MI-006-4	FRONT ARM - TOP	2
8	CAC50-046-3	CENTER ROLLER - 1.12 DIA.	1
9	CAC50-017-3	SHAFT - KNIFE ARM	1
10	CAC50-038-3	THREADED SUPPORT SHAFT	1
11	CAC50MI-005-4	FRONT ARM - MAIN	1
12	-----	M5 X FH SCREW	13
13	CAC50-013-3	KNIFE BRACKET	1
14	-----	M5 X 12 BUTTON HD. SCREW	2
N/S	PSR603	SPRING	1

# KNIFE GUARD ASSEMBLY

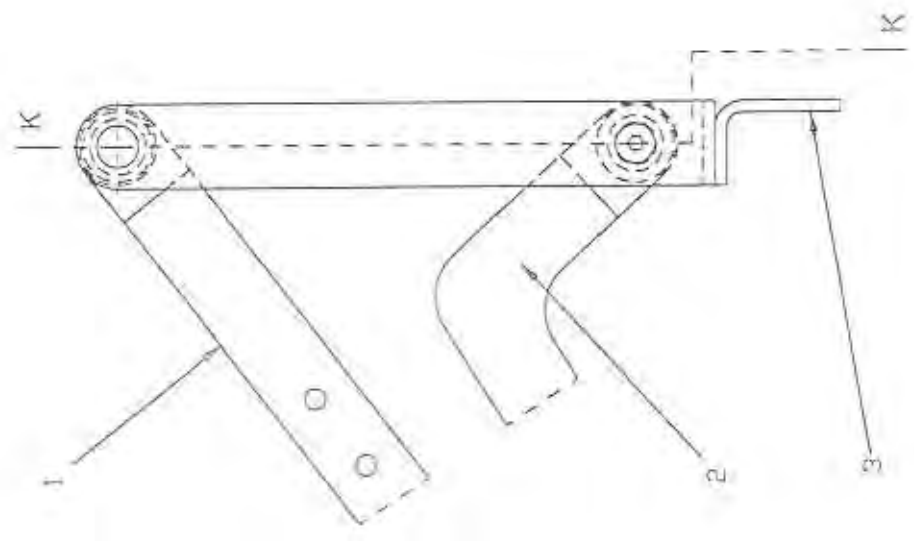
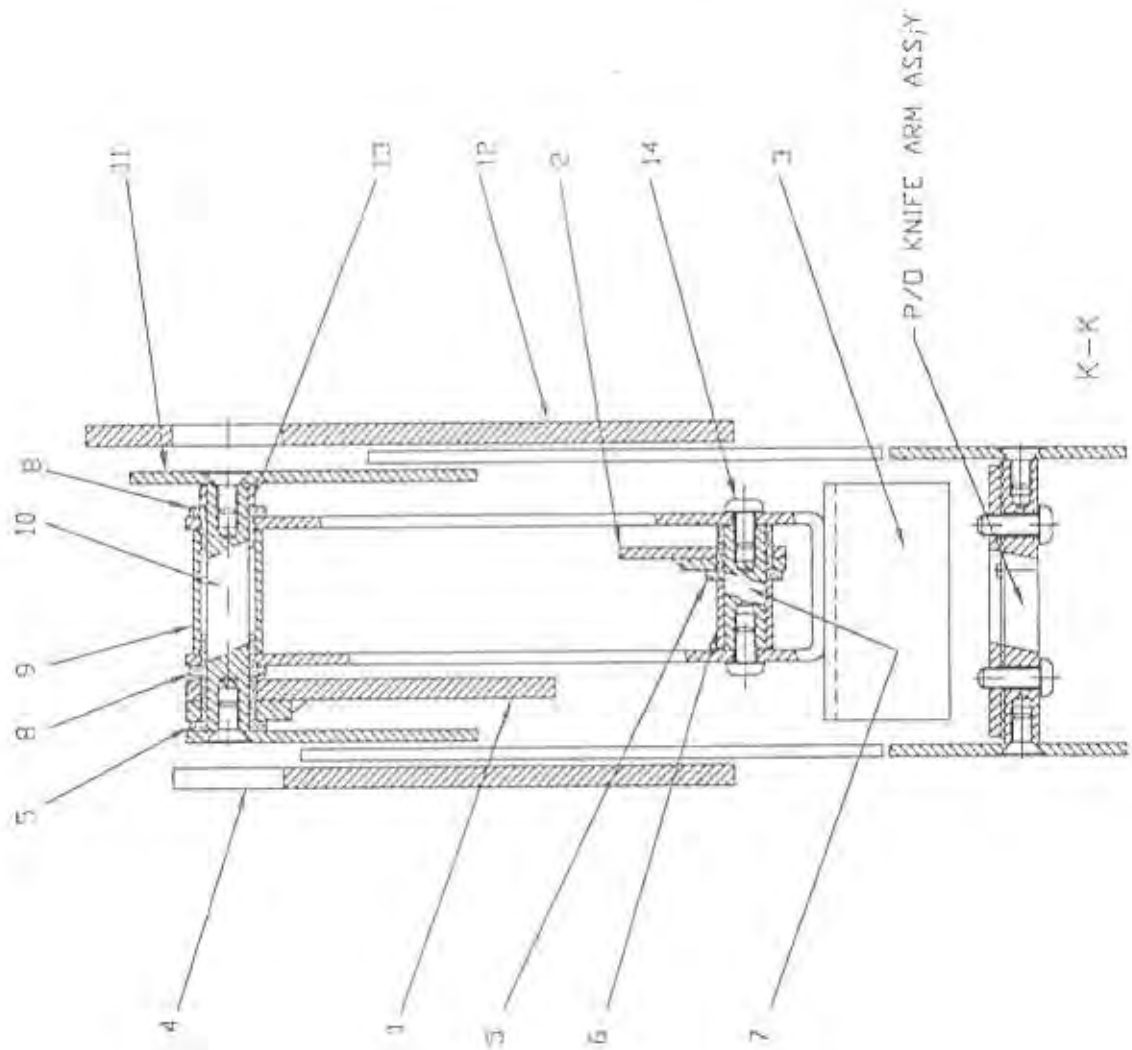

## KNIFE GUARD ASSEMBLY

KEY	PART NUMBER	DESCRIPTION	QTY
1	CAC50-003-4	CONNECTING LINK - ARM	1
2	CAC50-004-4	CONN. LINK - KNIFE GUARD	1
3	CAC50-011MI-4	KNIFE GUARD	1
4	CAC50MI-019-5	FRAME - TOP	1
5	50186-007	BRONZE FLANGE BUSHING 3/8 X 1/2 X 1/2	6
6	CAC50-041-3	SPACER - KNIFE GUARD	1
7	CAC50-048-3	SHAFT - KNIFE GUARD	1
8	50186-039	BRONZE FLANGE BUSHING 3/8 X 1/2 X 3/8	4
9	PSC301110-3	SPACER 1/2 ID X 1 1/8 LONG	1
10	CAC50-036-3	SHAFT - WIPE ROLLER	3
11	CAC50MI-005-4	FRONT ARM - MAIN	1
12	CAC50MI-102-6	FRAME - MAIN	1
13	CAC50-040-3	SPACER - CONN. ARM KNIFE COVER	1
14	-----	M5 X 10 BUTTON HD. SCREW	3

# CLUTCH ROLLER ASSEMBLY

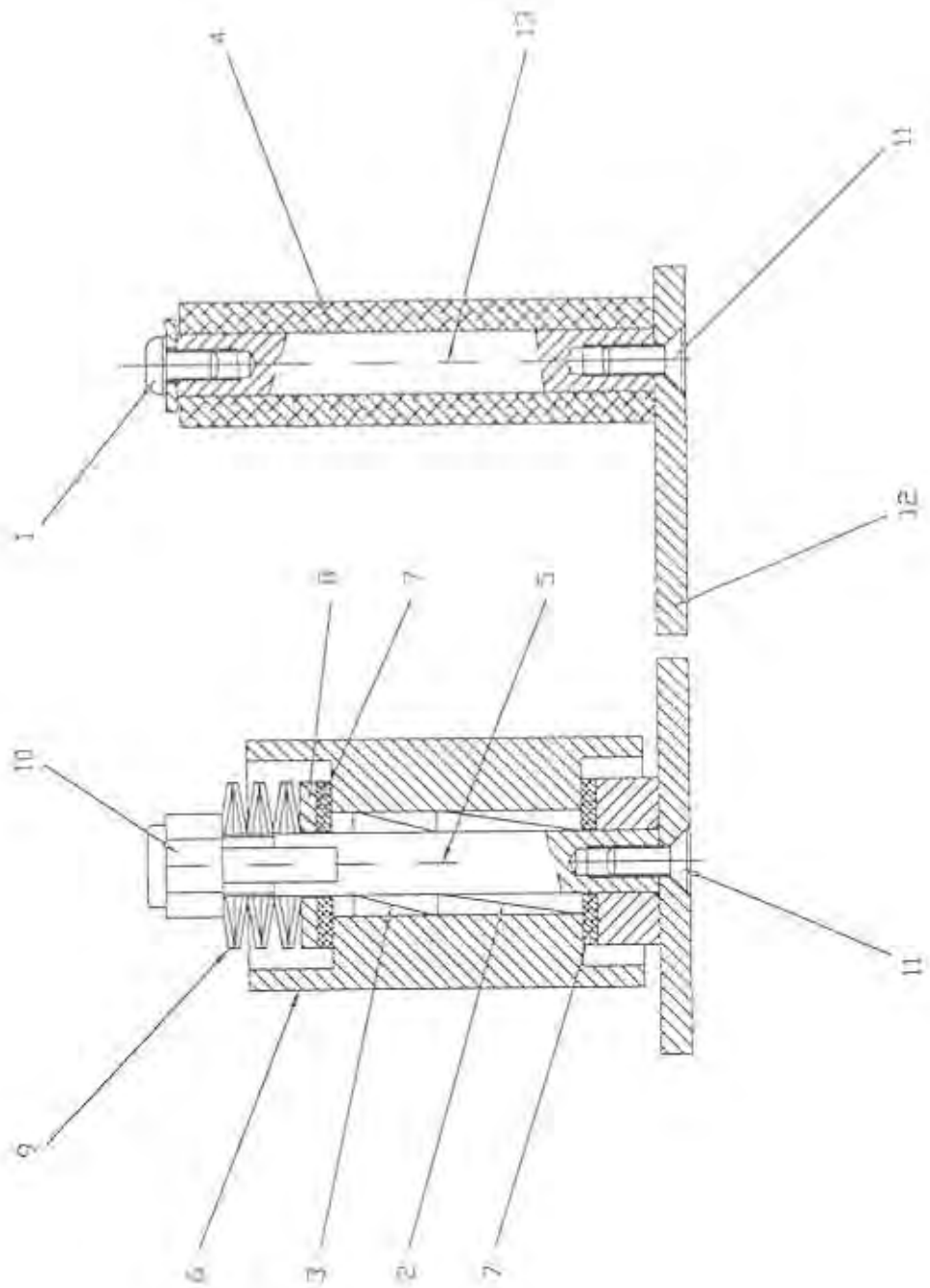

## CLUTCH ROLLER ASSEMBLY

KEY	PART NUMBER	DESCRIPTION	QTY
1	-----	M5 X 10 BUTTON HD. SCREW	3
2	J205-PS	TORRINGTON BEARING	1
3	J206-PS	TORRINGTON BEARING	1
4	PSC49-3	IDLER ROLLER ¾" DIA.	1
5	CAC50-021-3	KNURLED ROLLER SHAFT	1
6	PSC321023-4	KNURLED ROLLER	1
7	PSC321031-3	BRAKE WASHER	2
8	PSC321032-3	LOCKING WASHER	1
9	PSC321039	SPRING WASHER	6
10	50299-028	NYLON INSERT LOCKOUT	1
11	-----	M5 X 12 FH SCREW	23
12	CAC50MI-102-6	FRAME - MAIN	1
13	CAC50-024-3	SHAFT - IDLER ROLLER	1

# TAPE CORE ASSEMBLY

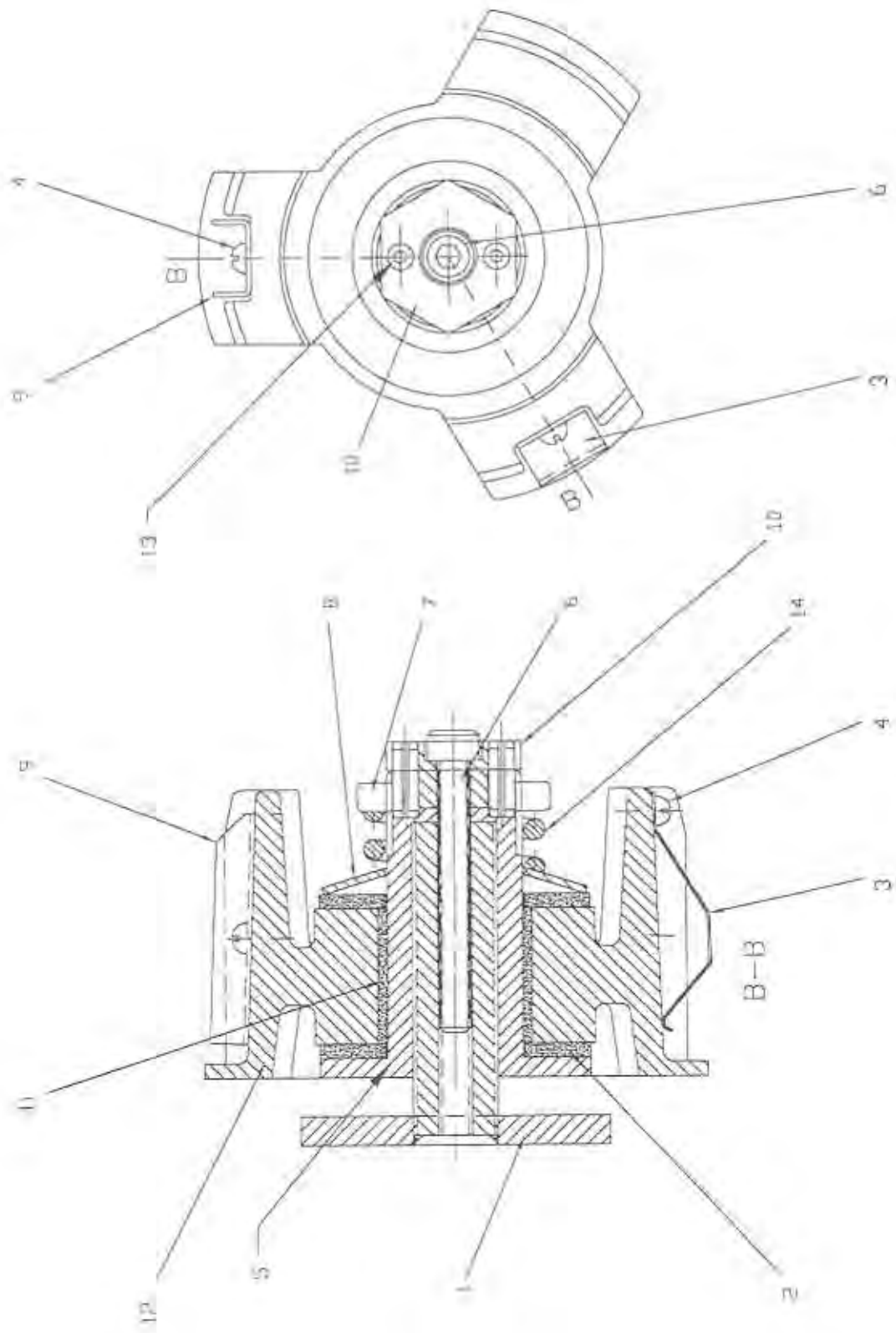

## TAPE CORE ASSEMBLY

KEY	PART NUMBER	DESCRIPTION	QTY
1	CAC50MI-102-6	FRAME - MAIN	1
2	PSC28-3	BRAKE WASHER	2
3	PSC88-3	TAPE SPRING	4
4	MS7M3-5	PHIL. HD M3 X 5	3
5	CAC50-096-4	TAPE CORE SHAFT THREADED	1
6	SPH-1030	SOCKET HD. CAP SCREW	1
7	PSC142-3	TAPE CORE NUT	1
8	PSC33	DISC SPRING	1
9	PSC144-3	TAPE HOLDER	1
10	CAC50-095-3	HEX LOCK NUT	1
11	PSC625	BUSHING	1
12	PSC30A-5	TAPE CORE CASTING	1
13	SPH-1049	DOWEL PIN	2
14	PSC33B-3	SPRING	1

## **TAPE CORE ASSEMBLY ADJUSTMENT PROCEDURES**

**(.TCA201 = 3" TAPE CORE AND .TCA301 = 2" TAPE CORE)**

### **STEP 1: UNLOCKING THE TAPE CORE FOR ADJUSTMENT:**

THERE IS A LOCKING BOLT USED TO MAINTAIN THE HEIGHT ADJUSTMENT OF THE TAPE CORE. THIS MUST BE LOOSENED TO CHANGE THE HEIGHT OF THE TAPE CORE. THIS WILL ALLOW YOU TO ADJUST THE HEIGHT OF THE TAPE (TRACKING) THROUGH THE CARTRIDGE. USING A 3 mm HEX KEY WRENCH TURN IN A COUNTERCLOCKWISE DIRECTION TO LOOSEN THE SOCKET HEAD CAP SCREW (SPH-1030). THEN TURN THE TAPE CORE NUT LP06B-039-3 (3") OR PSC142-3 (2") IN A COUNTERCLOCKWISE DIRECTION TO REMOVE DRAG FROM THE DISC SPRING (PSC33). BE SURE TO LOOSEN ENOUGH TO ALLOW THE TAPE CORE INTERNAL ASSEMBLY TO SPIN FREELY AND ADJUST UP AND DOWN.

### **STEP 2: ADJUSTING THE TAPE CORE HEIGHT:**

THE INTERNAL ASSEMBLY IS THREADED ON A STUD MOUNTED ON THE CARTRIDGE MILL STAND. BY HOLDING THE EXTERNAL PART OF THE TAPE CORE ASSEMBLY AND ROTATING THE HEX LOCK NUT CAC50-101-3 (3") OR CAC50-095-3 (2") THE INTERNAL ASSEMBLY WILL ROTATE CHANGING THE HEIGHT OF THE TAPE CORE ASSEMBLY. TURN IN A CLOCKWISE DIRECTION TO DECREASE THE HEIGHT AND IN A COUNTERCLOCKWISE DIRECTION TO INCREASE THE HEIGHT. ***DO NOT OVER TIGHTEN THE INTERNAL ASSEMBLY.*** THIS MAY CAUSE DAMAGE TO THE TAPE CORE ASSEMBLY. RUN THE TAPE THROUGH THE CARTRIDGE AND CHECK FOR PROPER TAPE POSITION. REPEAT ADJUSTMENT AS REQUIRED TO CENTER TAPE.

### **STEP 3: ADJUSTING TAPE ROLL BACK LASH OR FREE SPIN:**

THERE IS A DISC SPRING (PSC33) AND A SET OF BRAKE WASHERS (PSC28-3) USED TO SLOW THE FREE SPINNING OF THE TAPE ROLL CAUSED WHEN THE TAPE IS PULLED THROUGH THE CARTRIDGE. BY ROTATING THE TAPE CORE NUT LP06B-039-3 (3") OR PSC142-3 (2") IN A CLOCKWISE DIRECTION THIS WILL INCREASE THE DRAG FROM THE DISC SPRING (PSC33) RESTRICTING THE AMOUNT OF FREE SPIN. THIS SHOULD BE SET WITH JUST ENOUGH DRAG TO STOP THE FREE SPINNING. TOO MUCH OR TOO LITTLE WILL AFFECT THE CARTRIDGE TAPING PERFORMANCE. RUN TAPE THROUGH THE CARTRIDGE AND CHECK FOR TAPE ROLL FREE SPIN. REPEAT ADJUSTMENT AS REQUIRED TO SET TAPE ROLL FREE SPIN.

### **STEP 4: LOCKING THE TAPE CORE:**

AFTER THE TAPE IS CENTERED AND THE TAPE ROLL FREE SPIN IS PROPERLY ADJUSTED THE TAPE CORE SHOULD BE LOCKED INTO POSITION. USING A 3 mm HEX KEY WRENCH TURN IN A CLOCKWISE DIRECTION TO TIGHTEN THE SOCKET HEAD CAP SCREW (SPH-1030). THIS WILL INSURE THAT THE HEIGHT ADJUSTMENT IS MAINTAINED DURING OPERATION.