

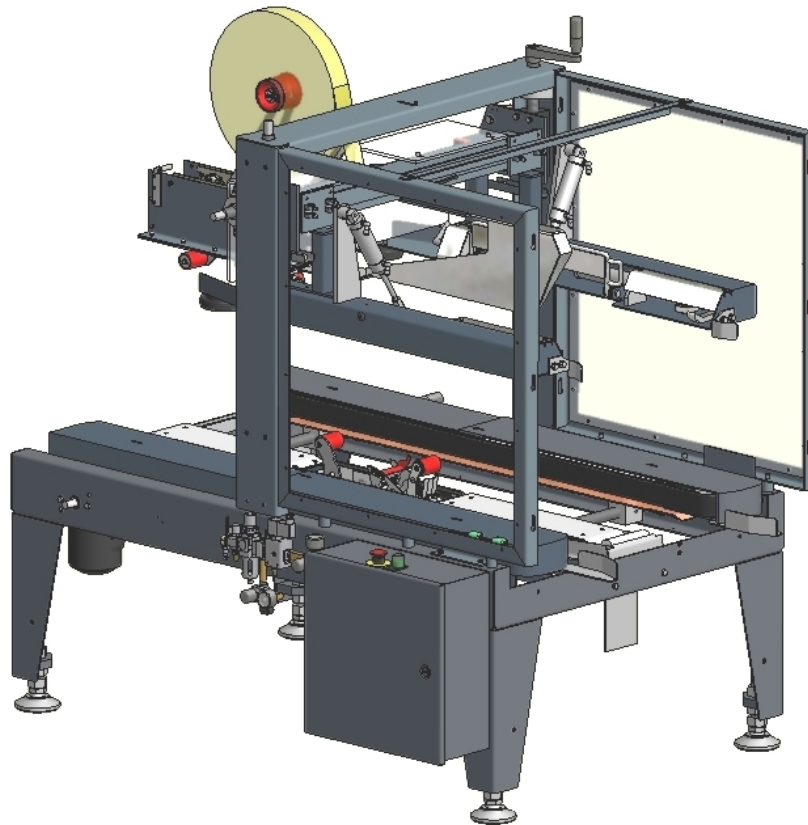

Little David™ Case Sealer

LD24 Uniform Side Belt Drive Fully Automatic Case Sealer



Version: 10/10/11 Rev A

Operator's Manual

LITTLE DAVID™ CASE SEALER

LD24 Operation

Copyright © Loveshaw
Loveshaw, Inc.
2206 Easton Turnpike, PO. Box 83
South Canaan, PA 18459
Tel: 1-800-962-2633 • 570-937-4921
Fax: 570-937-4016

www.loveshaw.com

ITW PADLOCKER, LTD.
Unit 9 Brunel Gate
West Portway Industrial Estate
Andover, Hampshire SP10 3SL
ENGLAND
Tel: 264-357511
Fax: 264-355964

Monday, October 10, 2011

Table of Contents

Chapter 1: Introduction	1
--------------------------------	----------

Chapter 2: Operating Safety	2
------------------------------------	----------

Chapter 3: Overview & Setup	7
--	----------

Chapter 4: Installation	13
--------------------------------	-----------

Chapter 5: Theory of Operation	15
---------------------------------------	-----------

Chapter 6: Machine Components	20
--------------------------------------	-----------

Chapter 7: Maintenance	29
-------------------------------	-----------

Chapter 8: Troubleshooting 38

Chapter 9: Warranty 40

Chapter 10: Assembly Drawings and Schematic 42

Introduction

Thank you for purchasing the Little David™ case sealer, the LD24. The LD24 is a fully-automatic side belt drive case sealer. The LD24 is a robust built 24/7 case sealer constructed of quality materials, robust drive motors, pneumatic and electrical components.. All employees who will be required to operate and maintain the case sealer **must** read this manual to ensure safe operation as well as proper set-up and maintenance throughout the life of the machine. After reading this manual, you will know how to perform the following functions,

- How to operate the machine safely.
- How to set the conveyor height of the machine
- How to set up and change over to different box sizes.
- How to set the machine to operate in automatic mode.
- How disable energy saving mode.
- How to adjust the pneumatic controls.
- How to adjust the moveable photoelectric sensors.
- Troubleshooting and replacing of worn or defective parts.

Throughout this manual there are several illustrations designed to help perform the variety of tasks described.

Operating Safety

Observe the warnings and cautions below when using the Little David LD24 case sealer. Within this manual on pages 4 -6, all safety labels are depicted with location and part number. If a safety label is missing or not legible it must be replaced immediately. Failure to follow safety labels can lead to injury or damage to the machine.

Instruction: Requirement to System Operation

Instruction: An electrical receptacle must be located near the machine. The line cord connection to the receptacle is the disconnect means for the machine. The receptacle must be located in an area that is easily accessible to all personnel.

Warning: Potential Bodily Injury

Warning: Always disconnect all sources of energy to the machine before performing maintenance. Sources of energy include electrical and pneumatic. Refer to your company's lock out tag out procedures.

Warning: Never bypass or remove safety guards from the machine or tape cartridge.

Warning: Never override safety devices such as Emergency Stop switches.

Warning: Never adjust the machine or tape cartridges when the machine is operating.

Warning: Never place hands or body inside confines of the machine unless top head assembly is locked in place and all power sources are locked out.

Warning: Never wear jewelry, loose clothing, such as ties, scarves etc and long hair must be pulled back when operating this machine.

Warning: Never pull a jammed box out of the machine while it is in operation. Stop machine and open the side drives and raise the head assembly.

Warning: When feeding a box into the machine manually avoid the rear flap folding mechanisms.

This manual contains operator information for Little David Case Sealer Equipment. It is directed toward the person who operates and maintains the machine. Read through the manual completely before operating the machine. Thereafter, refer to it as necessary.

Take special note of all warnings, cautions, and maintenance instructions. Like any other piece of equipment, the Little David Case Sealer functions best when maintained and used correctly.

Caution: Potential Machine Damage:

Caution: **Never push or drag machine across the floor with the top head assembly fully raised. Makes sure it is completely lowered.**

Caution: **Never pull the machine by the guards or side belt drives.**

Caution: **Provide and use proper electrical power.**

Caution: **Do not operate, maintain, or otherwise use this machine, except as described in this manual.**

Special instruction:

The case sealer incorporates removable side guards that allow access to the flap folder section of the machinery for maintenance convenience. **Never** operate the machine with these guards removed. Always use OSHA lock out / tag out procedures before servicing this or any machinery.

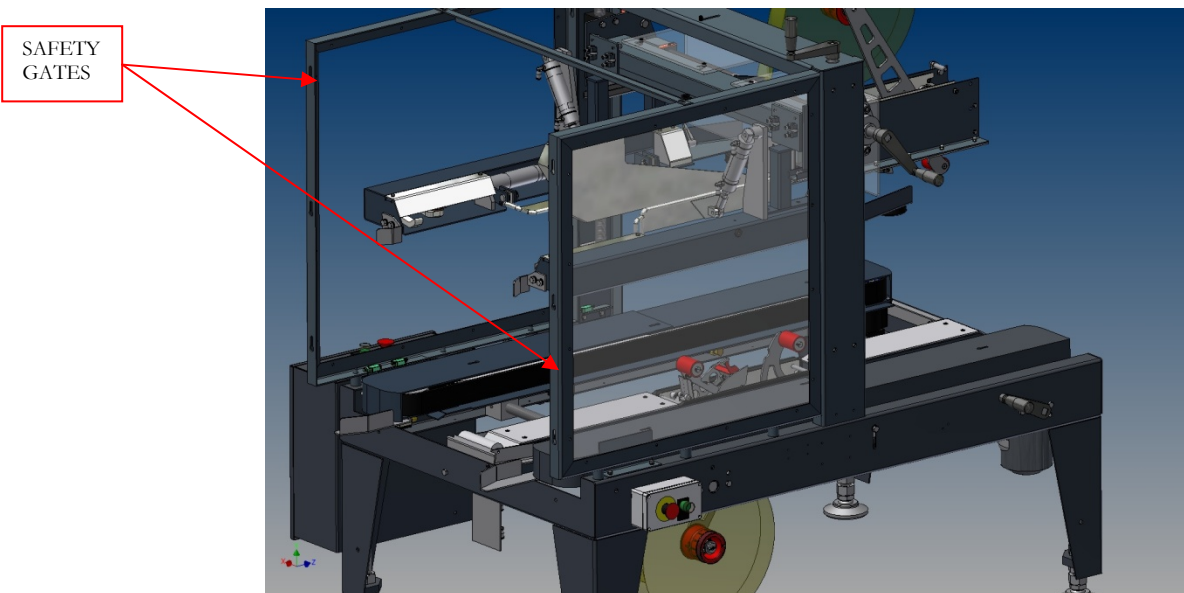

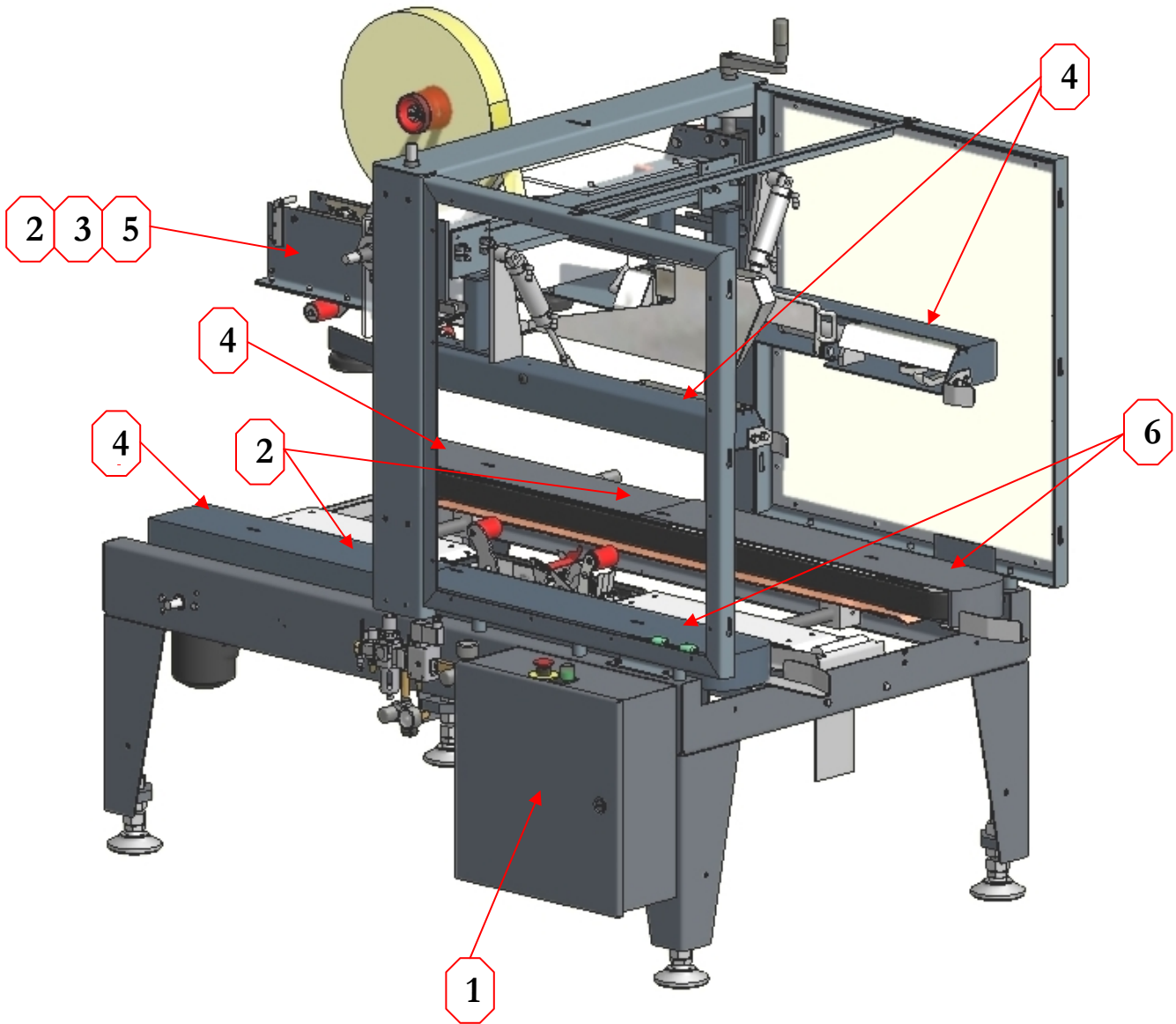

1

 <h1 style="margin: 0;">WARNING PRECAUCION</h1>	
<p>Arc Flash Hazard Appropriate PPE Required PELIGRO DE ARCO ELECTRICO USE EL EPP ADECUADO</p>	
<p>Do not operate controls or open covers without appropriate personal protection equipment.</p> <p>No opere los controles ni abra las cubiertas sin el equipo de protección personal adecuado.</p> <p>Failure to comply may result in injury or death!</p> <p>El no cumplir esta indicación puede resultar en lesiones o hasta la muerte.</p>	
<p><small>Refer to NFPA 70E for minimum PPE requirements Vea NFPA70E para consultar el PPE mínimo requerido</small></p>	



SL-0021

2

 <h2 style="margin: 0;">WARNING</h2>		 <h2 style="margin: 0;">PRECAUCION</h2>
<p>Blade hazard. Keep hands clear. Follow lockout procedure before servicing.</p>		<p>Riesgo con la cuchilla. Mantenga las manos alejadas.</p> <p>Antes de dar mantenimiento, desenergice, asegure y etiquete.</p>

SL-0001

3

 <h2 style="margin: 0;">WARNING</h2>		 <h2 style="margin: 0;">PRECAUCION</h2>
<p>Read and understand operator's manual before using this machine.</p> <p>Failure to follow operating instructions could result in death or serious injury.</p>		<p>Lea y entienda el manual operativo antes de utilizar esta maquina.</p> <p>El no cumplir con las instrucciones operativas puede resultar en lesiones serias o incluso la muerte.</p>

SL-0002

4

 CAUTION		 PRECAUCION
<p>Moving parts can pinch or cut. Do not operate with guard removed. Lockout and tagout before servicing.</p>		<p>Las partes móviles le pueden machucar o cortar. No opere sin la guarda en posición. Antes de dar mantenimiento desenergice, asegure y etiquete.</p>

SL-0004



5

 CAUTION PRECAUCION

<ul style="list-style-type: none"> ● PINCH POINT ● PUNTO DE PELLIZCO ● HANDS CAN BE INJURED ● SE PUEDE LASTIMAR LA MANO ● KEEP HANDS AWAY FROM ROLLERS ● MANTENGA LAS MANOS ALEJADAS DE LOS RODILLOS

SL-0003

6

 WARNING		 PRECAUCION
<p>Entanglement hazard. Rotating parts. Do NOT operate with exposed long hair, jewelry or loose clothing.</p>		<p>Riesgo de enredo. Partes rotativas. No operar con cabello largo suelto, joyería o ropa hogada.</p>

SL-0006

Case Sealer Sections

Overview

This manual covers several parts of the machine. The following diagram identifies the key sections of the machine.

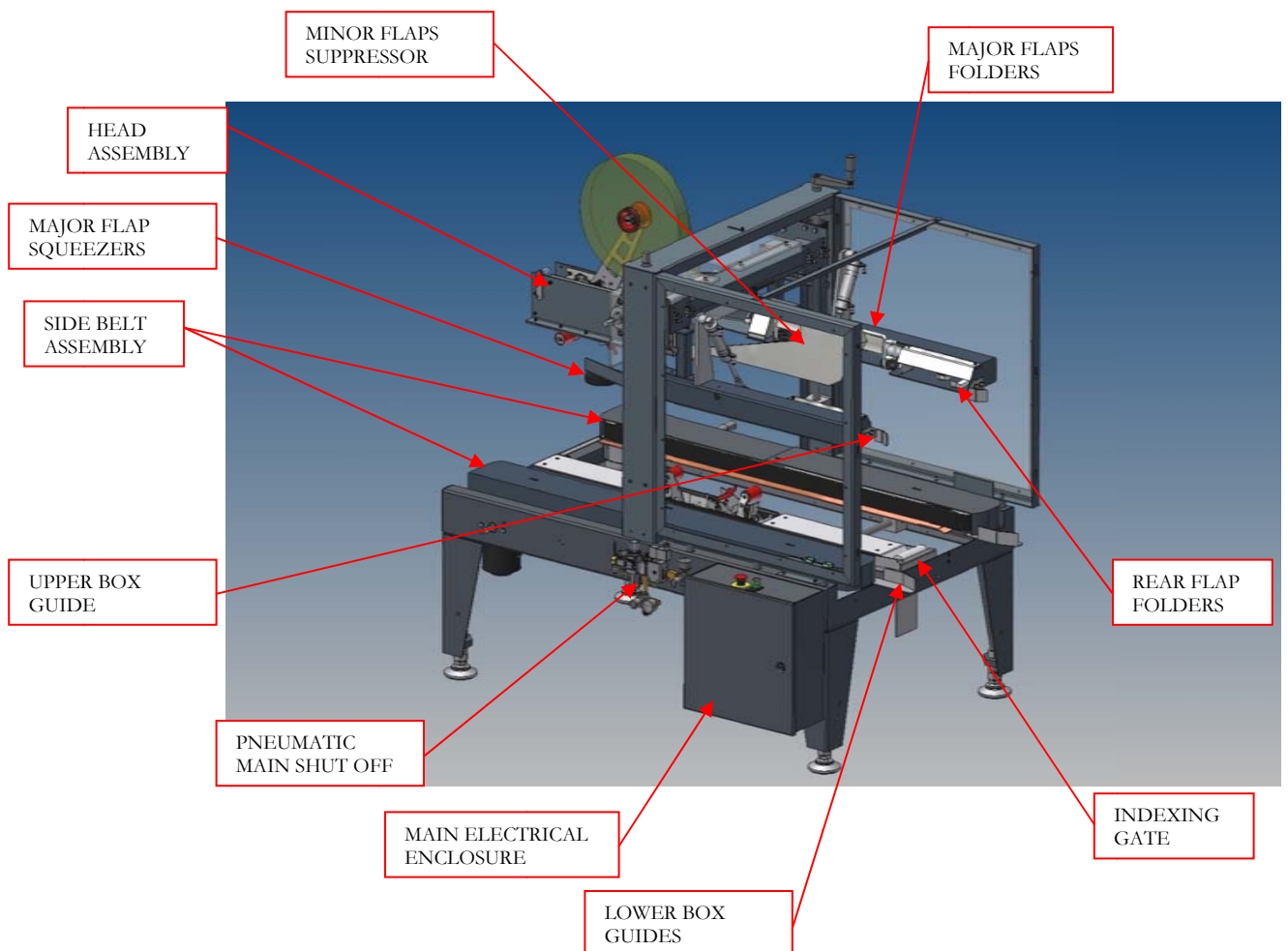

Machine Specifications

Machine dimensions:

- Height: 62" @ 22 1/4" conveyor height
- Length:
 - 64 3/4" overall including box guides.
 - 58" overall frame length (Conveyor opening dimension)
- Width: 49" main electrical enclosure to opposite side crank handle.
- Conveyor height: 22 1/4" to 30 1/4" – Standard

Electrical Requirements:

- Standard Voltage: 120/1/60 with 15 amp dedicated service.
- Optional voltages are available consult factory.

Operating speed:

- Standard belt speed: 100 ft/min

Air Requirement:

- 5 scfm @ 80 psi

Machine box capacity:

- Length: - 8” to 24”
- Width: - 6” to 18”
- Height: 4” to 18”

Machine Setup:

The following steps describe how to set up and change the machine over from one size to another.

1. Insure that the machine is in Emergency Stop mode.
2. Measure the box height and width. Measure the box height with the all the flaps folded. This measurement is critical and it is the outside dimensions of the box. *Never* rely on the measurements that maybe listed on the box itself,

these measurements are usually the inside dimensions of the box.

3. Adjust the height assembly of the head to the measured height of the box to be processed. There is a crank handle on the top of the machine to raise or lower the head assembly. There are scales on the main upright structure of the machine with an integral pointer and a scale.
4. Set the width of the top flap folder assembly and side belt drive motors. This is accomplished by using the crank handles supplied on both adjusting lead screws. There are integral scales and pointers on each adjustment.
5. Set the position of the minor flaps suppressor. The position of the flap suppressor is dictated by the width of the box. Loosen the locking handle located at the in feed of the machine on the center of the top head assembly. Slide the suppressor until the scale located on the top of the suppressor is at the width of the box to be processed. The leading edge of the suppressor mounting bracket is the indicating pointer for the scale.
6. Start the machine and try processing one box. If the box does not properly fold flaps first check all the settings made for the box, do not adjust any air pressures or photoelectric sensor positions. Make sure that the contents in the box itself do not exceed the height of the score lines of the box. Make sure that the minor and major flaps are not interfering with each other. Insure that the major flaps do not overlap.

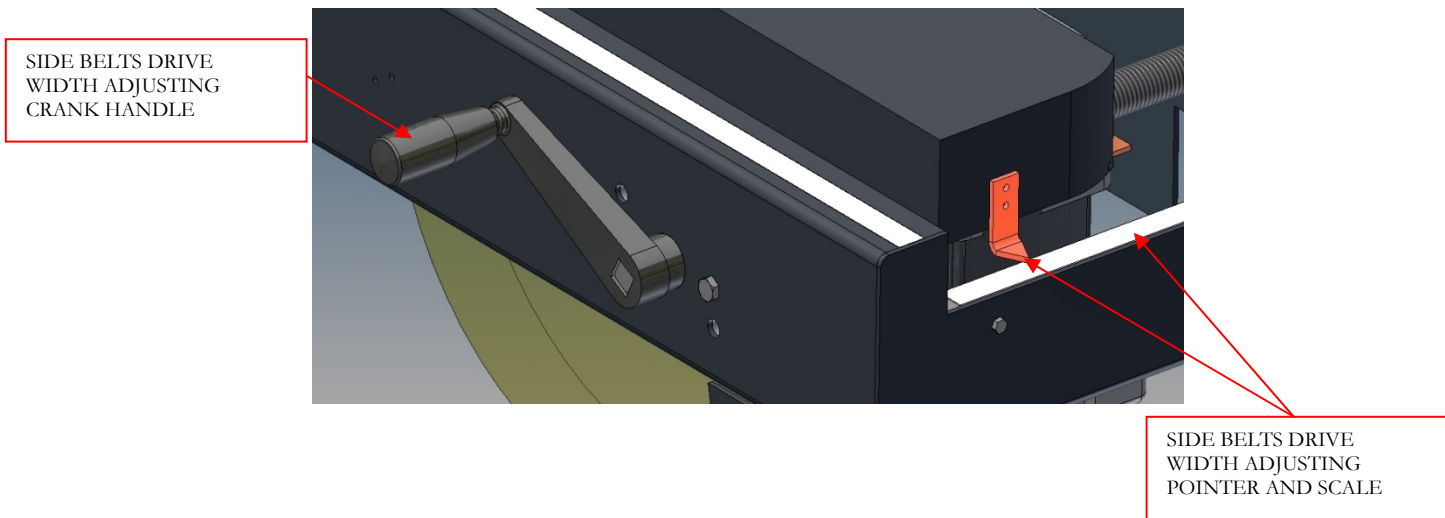
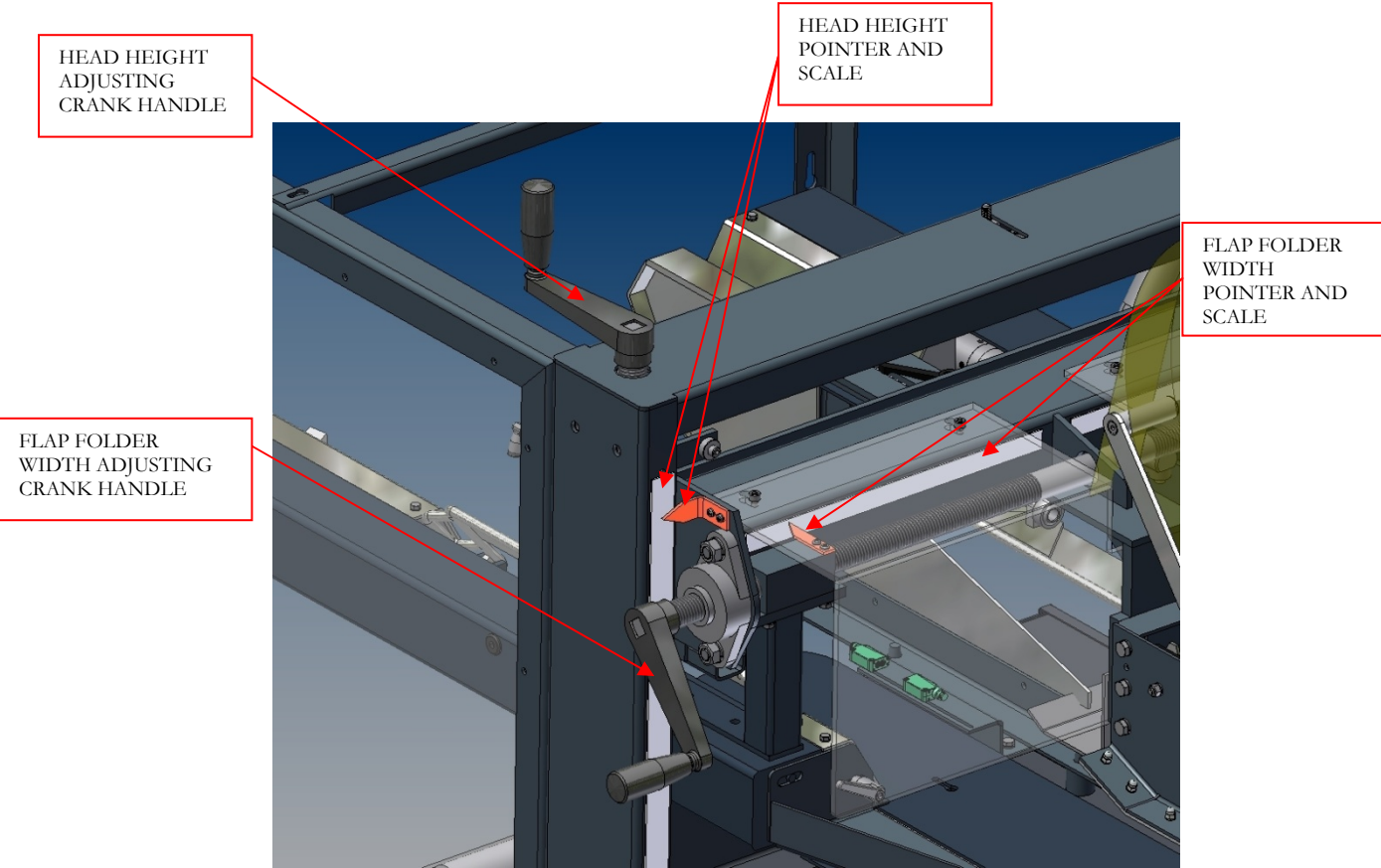

MINOR FLAPS
SUPPRESSOR POINER
AND SCALE

MINOR FLAP SUPPRESSOR
SLIDE ADJUSTOR
LOCKING HANDLE

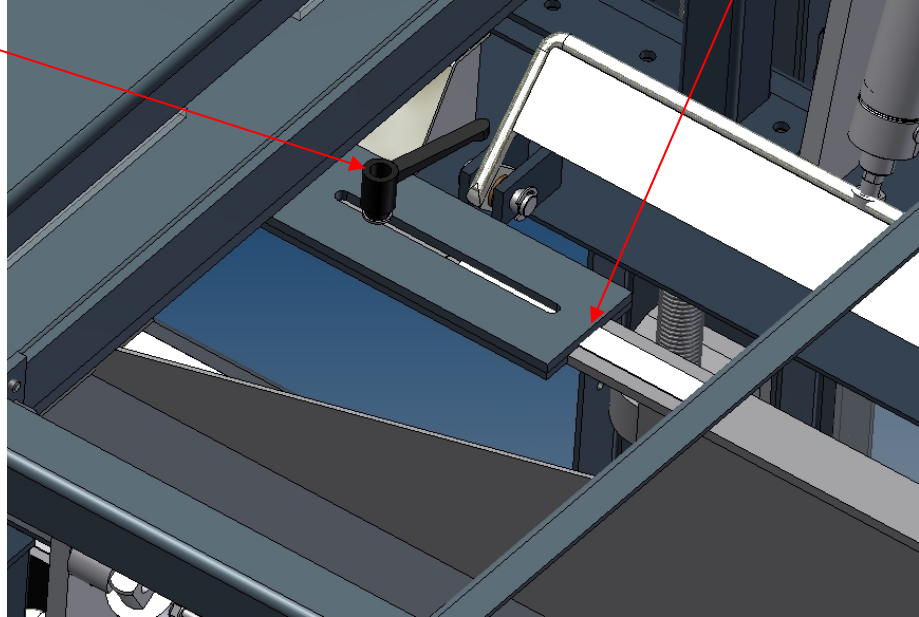

Installation

Always check for any signs that the machine may have been damaged before fully removing it from the shipping skid. If the machine arrives damaged contact Loveshaw immediately to help in filing a claim with the shipping company.

Section 1: Placing the Machine

The case sealer is fully assembled and ready for operation.

Step One: Carefully remove the machine from the shipping skid. Remove all fasteners and brackets holding the machine to the skid. Remove head assembly hold down strapping and support materials.

Step Two: *Take care removing the machine from the skid as it weighs 800 pounds! Use a forklift or similar device to complete this task*

Step Three: Move machine to the designate location. It may be necessary to adjust the conveyor height of the machine. The legs on the machine are adjustable by loosening the jam nuts on the threaded rod and turning the nuts until the desired height is achieved. (Refer to figure on page 7)

Step Four: Connect the utilities to the machine, compressed air and electricity.

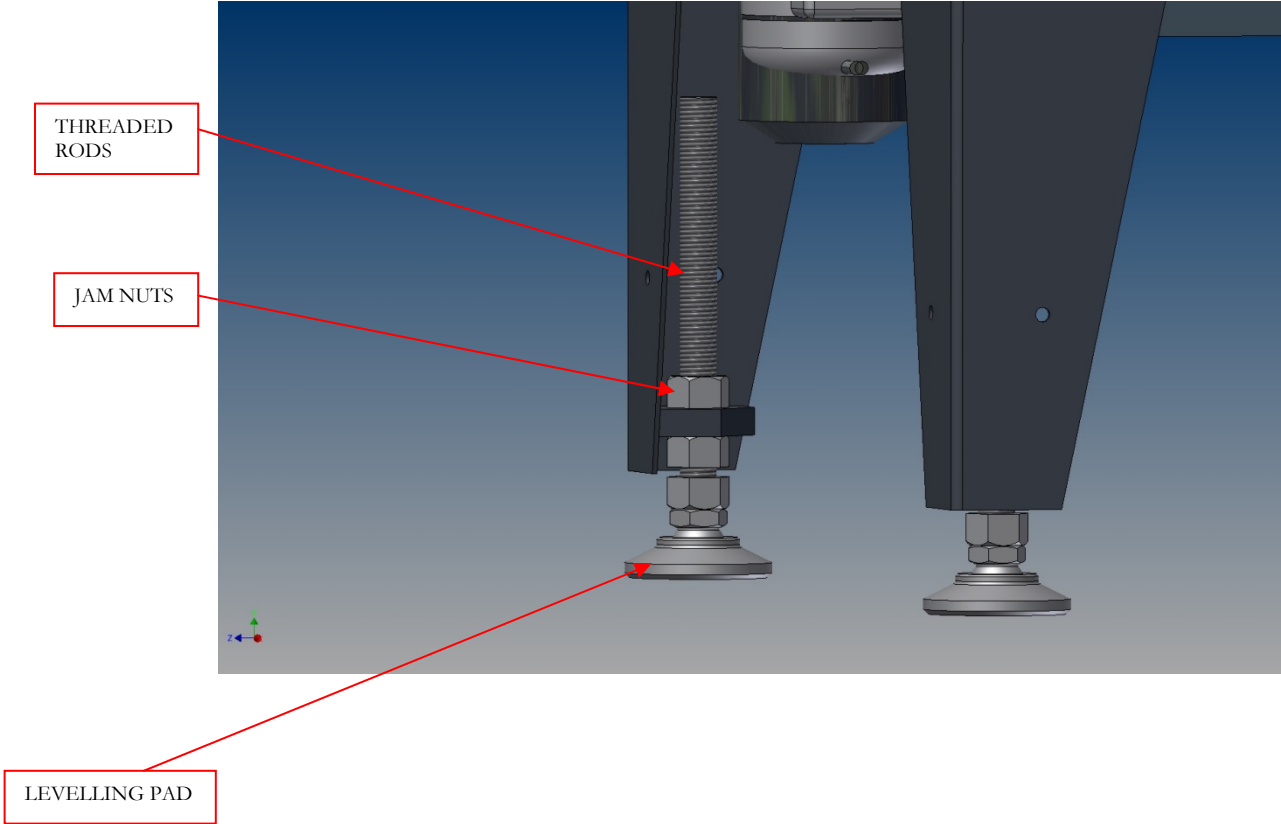

Theory of Operation

LD24

The LD24 will automatically fold all four top flaps and apply tape to the top and bottom of corrugated cardboard boxes. The LD24 provides indexing which maintains proper spacing between boxes that are being processed by the machine.

With the machine started, a box either fed by powered conveyor or hand enters the machine. The entrance photoelectric sensor “PE1” detects the leading edge of the box and the programmable logic controller (PLC) signals the in feed indexing gate to rise, energizing solenoid valve “SV4”. Raising the in feed indexing gate stops any other boxes from entering the machine until the previous box has exited the folding section of the machine. When the box enters the machine two side belts, one on each side contacts the box and pulls it forward through the machine. The box will travel past “PE1” signaling the plc to energize solenoid valve “SV2” folding the rear minor flap downward towards the exit end of the machine, simultaneously the front leading minor flap is folded downward by the suppressor. As the box moves forward through the machine the front leading flap will contact the stationary suppressor and the flap will be plowed down. The box will continue through the machine until photoelectric sensor “PE2” becomes unblocked, signaling solenoid valve “SV3” to energize folding the two major flaps downward while de-energizing “SV2” resetting the rear minor flap folder. The box will continue forward until the box travels under and over the tape cartridges while the top major flaps are butted together by squeezer rollers. Photoelectric sensor “PE3” will be unblocked

and solenoid valve “SV3” and “SV4” de-energize resetting the in feed indexing gate and the major flap folders. The box will continue to the exit of the machine as the next box is allowed to enter the machine re-starting the cycle.

Key design features:

Standard features:

The LD24 incorporates numerous features to insure quality folding and taping of boxes being processed. All functions of the machine are controlled by a programmable logic controller. (plc) The flaps are folded sequentially to insure limited box jamming. Photoelectric sensors identify box position without contacting and potentially damaging boxes. The machine incorporates the ability to operate and set up the machine from either side. The machine is standardly equipped with a remote operator station as well as removable crank handles which can be used from either side of the machine. The machine also incorporates an indexing gate to meter the flow of the boxes into the machine, and top flap squeezers which butt the major flaps together before tape is applied to the top of the box. The LD24 also has automatic side belt tensioning, which tensions the side belts consistently and individually through the life of the belts. All photoelectric sensors and solenoid valves are quick disconnection types to reduce down time.

Optional features:

Energy Saving Mode

The LD24 is factory set to operate in energy saving mode which will shut the machine down after 10 minutes of in activity. (Boxes not entering the machine) The mode can be disabled if not desired by removing a yellow jumper wire from terminal 100 to terminal 10 on the terminal strip in the main electrical enclosure. Remove the wire completely from each terminal, failure to do so can cause damage.

Additional Options

The LD24 can be fitted with top and bottom low tape detection, large range adjustable height legs, various voltages, additional emergency stop push buttons, in feed or exit pack tables and wash down friendly packages. The LD24 can also be directly connected to the CF5 semi automatic box erector.

Operating the machine:

Make sure that all guards are in place before starting the machine. With both Emergency Stop switches extended press the start pushbutton. The side belt motors will start to rotate and the main air valve will open allowing air into the system. Test each emergency stop pushbutton at the start of each shift to be sure that they operational. When de-pressed the Emergency stop switch must stop the machine immediately and not allow the machine to be restarted. If the switches are not operating this way do not operate the machine and inform your plant's

supervisor and the maintenance department. Never operate a machine that is not working properly.

With the machine started introduce a box to the infeed of the machine. Photoeye PE1 will become blocked raising the indexing gate. As the box moves through the machine PE1 will become unblocked and the rear flap folders will extend outward and fold the rear minor flap of the box down. The suppressor that folded the front minor flap downward will hold the rear minor flap down after it is folded. Photoeye PE2 will become unblocked by the box and the major flap folders will extend and fold the major flaps completely. Photoeye PE3 will then become unblocked by the box and the major flap folders will reset and the indexing gate will drop to let the next box in.

Photoeye PE1 is factory set to be all the way towards the front of machine in the slot of the mounting bracket. Moving the photoeye forward towards the exit of the machine will delay the operation of the rear flap folders. Photoeye PE2 is set 2 1/2" in front of PE1, that is the distance between the photoeye housings. Moving PE2 towards the exit end of the machine will delay when the major flap folders will extend, and moving the photo eye towards the front of the machine will make the major flap folders earlier. Changing positions of the photoeyes should be a last resort if having troubles processing boxes. Double check all the box change over setting first and the air pressure settings. Make sure the box measurements taken before set up were accurate. Make certain that the contents in the box is not higher than the score lines of the box. This will impede the machine from folding flaps.

To clear a box jam emergency stop the machine, open the side drives and raise the head assembly. It is possible to sometimes clear a jam by first emergency stopping the machine. Reaching

into the machines and manually folding the top flaps. Re-start the machine with the box in it. The major flap folders will extend to hold the major flaps downward as the machine is re-started and the box will exit the machine.

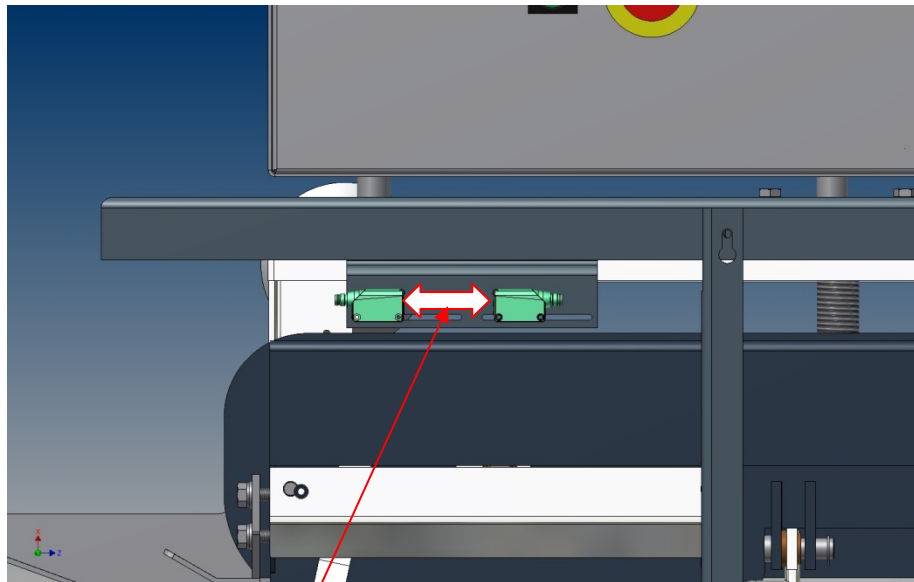

2 1/2" BETWEEN
PHOTOEYES

Machine Components

Control Station

There are two controls stations on the machine. One is integral to the main electrical enclosure and the other one is located on the opposite side of the machine directly across from the main enclosure. The pushbuttons are high quality, touch safe UL and CE approved.

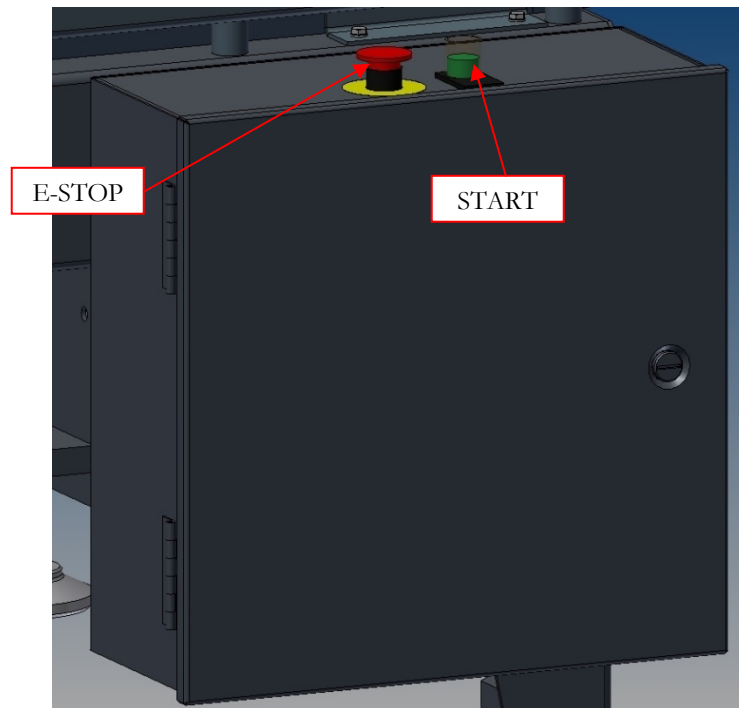

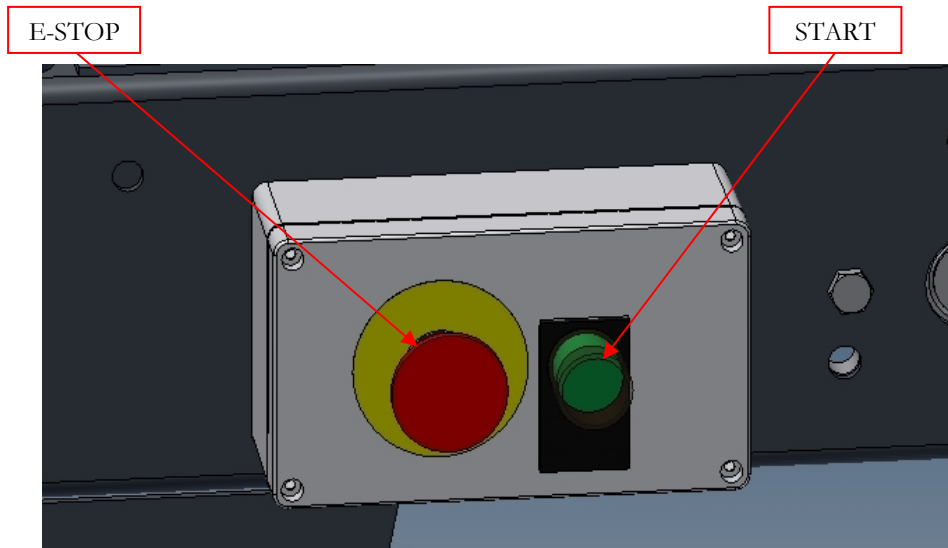

Pneumatic regulators

The regulators optimize the machine for the customers' specific needs. Regulator "R1" controls the main incoming air pressure. The machine is designed to operate optimally at 80 PSI.

Regulator "R2" controls the rear minor and major flap folder mechanism. The folders are design to operate optimally at 60 PSI. The regulator controls the force at which the rear minor flap folder, folds the flap downward. The regulator only controls the inward force. The flap folder retracts back to its home position via an internal spring in the air cylinder. This is designed in such a manner to have the rear minor flap folders retract without the possibly of injury. The major flap folders movement is controlled in both directions by the regulator.

Regulator "R3" controls the tension of the two side belts. Internally in the side belt drive assembly is a spring loaded air cylinder. When the dump valve SV1 is energized the side belt tensioning air cylinders are extended and the side belts are

tensioned. When SV1 is de-energized the side belt drives tension force is decreased to the force being exerted by the spring loaded cylinders. The spring loaded cylinders are being utilized to insure that the center guided side belt cannot fall out of the guides or drive rollers.

Regulator “R4” controls the force in which the indexing gate rises with. The regulator must be set at a pressure which will allow it to extend upwards when a box is not on top of it. The pressure may have to be increased dependant on back pressure from the in feed conveyor, or processing rate of the box entering the machine. When feeding boxes into the machine using a pack table it is preferable to turn the pressure completely down.

FACTORY SETTINGS

REGULATOR	DESCRIPTION	PRESSURE
R1	MAIN PRESSURE	80 PSI
R2	FLAP FOLDERS	60 PSI
R3	BELT TENSION	80 PSI
R4	INDEXING GATE	25 PSI

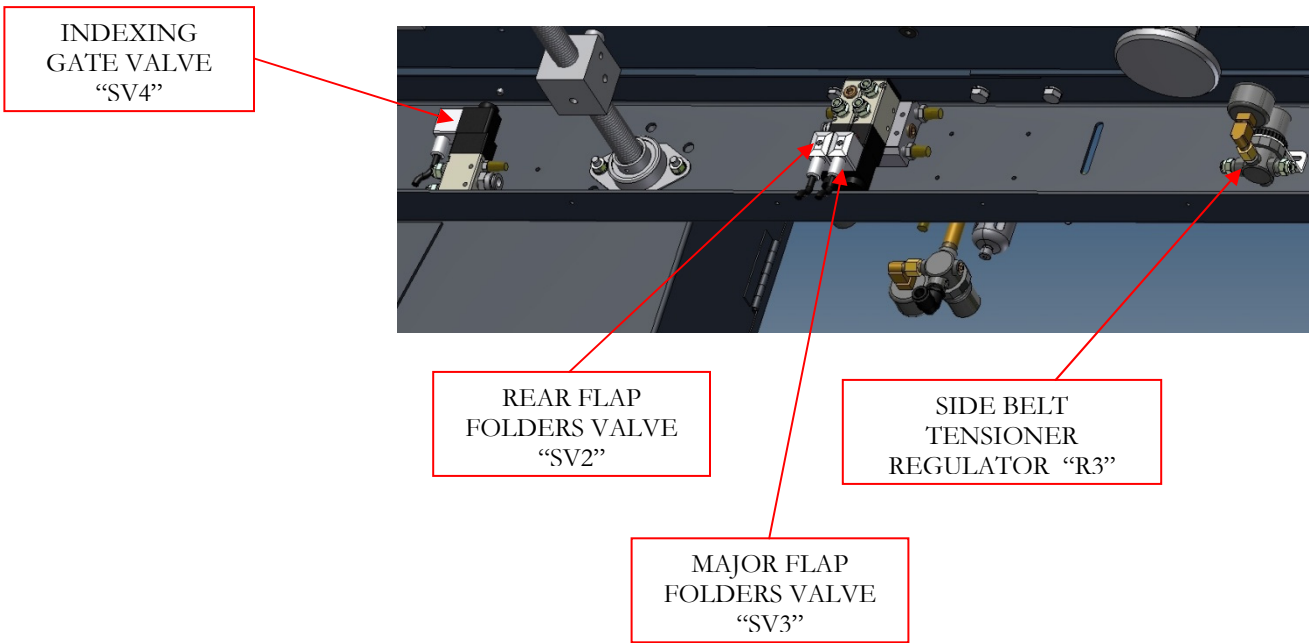
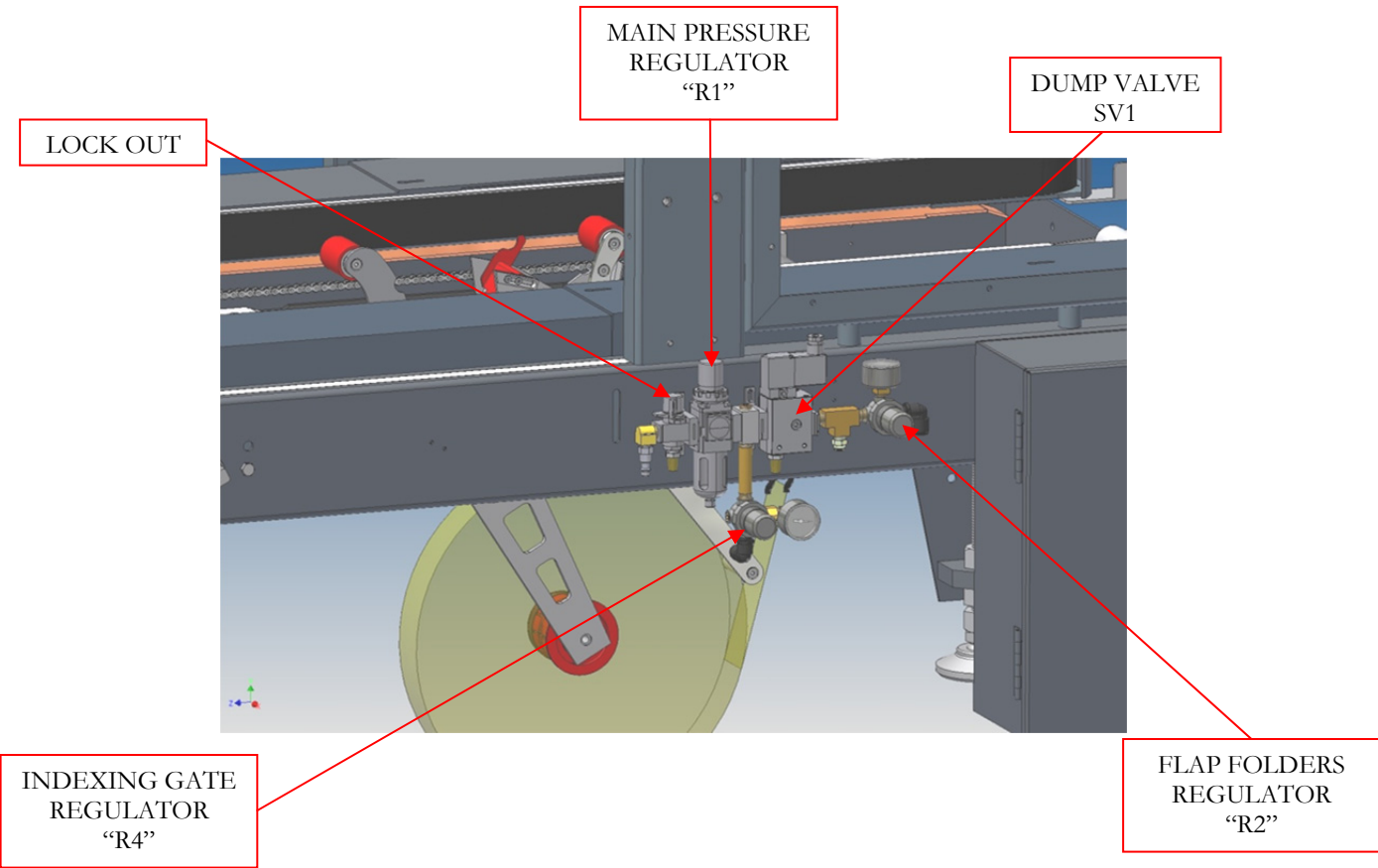

Side Belt Drive Assembly

The side belt drive assembly consist of a center guided belt, a 1/5 hp gear motor, drive and idler roller, belt backing plate, and spring loaded air cylinder. There are two side belt drive assembly per machine, one on each side. They are used to drive the box from the entrance to the exit of the machine. The distance between the side belts are adjusted via two acme thread lead screws and four lead nuts. The side belt assemblies each have two leads nut attached to them. The individual belt drives lead nuts are threaded the same direction; however they are threaded opposite on the other belt drive assembly. The Acme thread lead screws are also threaded opposite hand from one end to the other. As the lead screws are rotated the side belt drives will either move in toward each other or away from each other. In order for the machine to operate properly the side belt drives must be set to a width that will contact both sides of the box equally. If the distance between the side belt drives is too wide the box will not move or possibly stall. If the distance between the drives is too narrow the box may not enter the machine or the drive motors may stall. The proper way to set the width of the side belts is to put the box into the machine with the machine not running. Rotate the lead screws until the side belts just touch each side of the box, try pulling the box out of the machine. You should feel moderate resistance but will be able to pull the box out. Start the machine and begin processing boxes. If stalling occurs it may be necessary to adjust belts in closer together. Adjustments **must** be made in small increments. Closing the side belt drives too tightly will also cause stalling.

Side belt tensioning is obtained by the use of a spring loaded out air cylinder. The air cylinder when under pressure will extend outward pushing the side belt outward towards the front of the machine. The air cylinder allows for full tensioning trough out the life of the belt. The air cylinder was an integral spring which

also pushes the side belt out wards towards the front of the machine. This force is utilized to merely hold the side belt in the belt guide, drive and idler roller when air pressure is not present. It simply stops the belt from sagging.

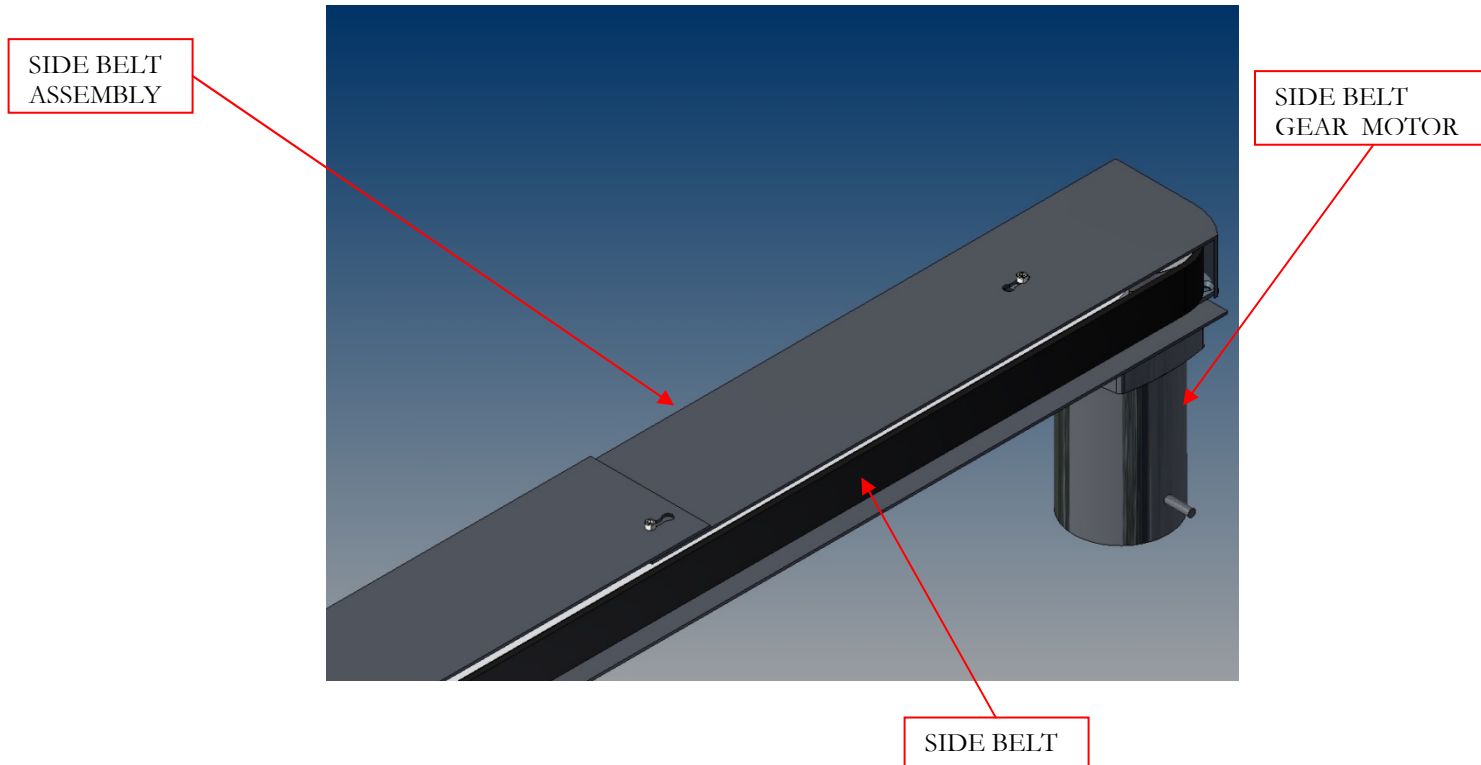

Top Head Assembly

The top head assembly consists of rear minor flap folder, major flap folder, top flap squeezers and a tape cartridge. The entire assembly is raised and lowered via lead screws. The rear minor flap folders, major flap folders and squeezers width is adjust via lead screws identically in the same manner as the side belt drives.

There are scales on both the height and width adjustments of the head assembly. Simply measure the height of the box with all flaps folded and then the width of the box. Turn the lead screw on top of the machine and set the height of the head. Now turn the lead screw on the side of the head assembly and set the width.

The head height can be micro adjusted while processing boxes if the top flaps are either not being folded down completely or if the major flaps are being damaged by the machine. It is never advisable to make large scale adjustments while the machine is operating.

The head width adjust can also be micro adjusted while the machine is processing boxes. If boxes are struggling to enter the machine the top head assembly can be opened wider. The squeezers wheels on factory set up are approximately 1/8" narrower than the front in feed of the head assembly. There should be a 1/4" clearance at the in feed of the head assembly while having sufficient flap squeezing force. There is an adjustment on each squeezer wheel to enhance flap squeezing if necessary. Make sure that both wheels are set to the same measurement on each side. Never have one wheel out further than the other, it can cause box jamming or machine damage.

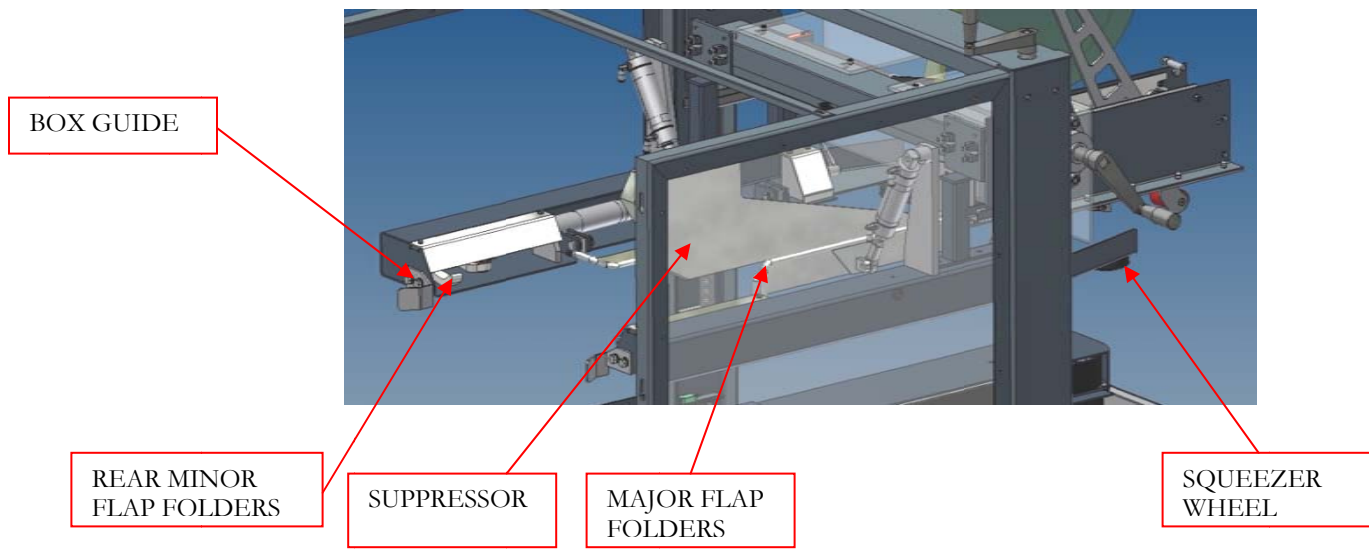

Electrical enclosure assembly

The electrical enclosure assembly is located on the left hand side of the machine in reference from the in feed of the machine. The enclosure consists of a red mushroom head twist to release emergency stop switch and a flush head green machine start push button. Inside the enclosure is housed the electrical panel assembly. The panel assembly consists of a programmable logic controller, twenty four volt DC power supply, control relay, fuse holders, wire terminal blocks and two motor starters with overload relays.

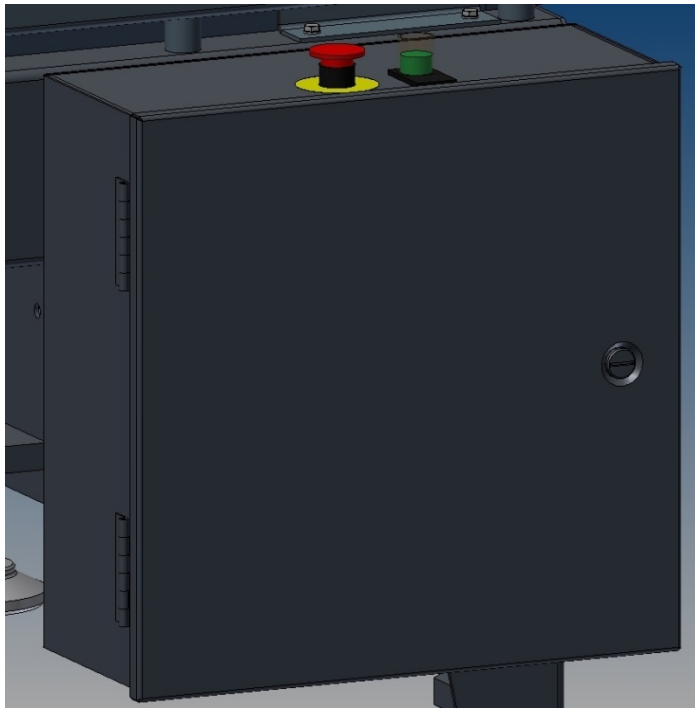

Remote operator station

The remote operator assembly is located on the right hand side of the machine in reference from the in feed of the machine. The assembly consists of a red mushroom head twist to release emergency stop switch and a flush head green machine start push button.

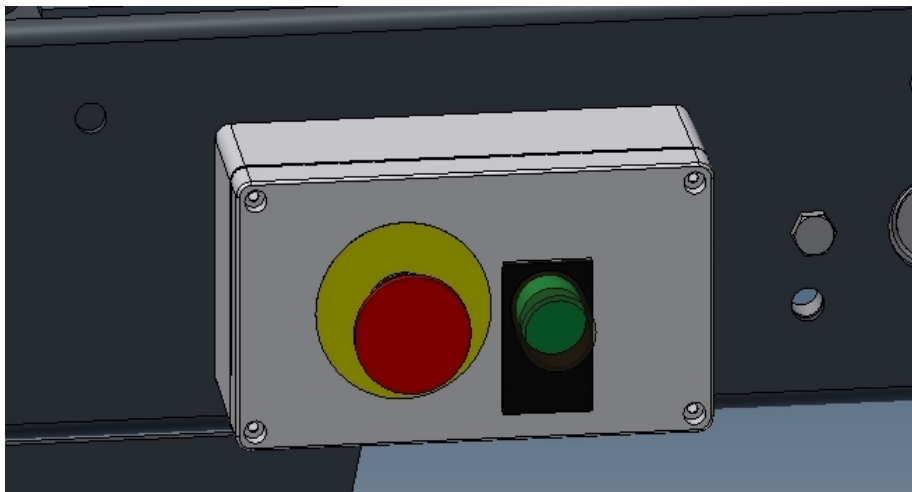

Maintenance

Safety: **NEVER** perform any maintenance on the LDXRTB without first following your company's **LOCKOUT / TAG OUT** procedures.

Side Belt replacement

To change a worn belt first follow your companies lock out / tag out procedures. With the machine in a de-energized state loosen the 6mm socket head screw that holds the top covers in place. Do not try to completely remove this fastener; it is designed to not be removed. With the fastener loosened slide the front top cover towards the in feed of the machine and remove it completely. Now slide the rear front cover towards the exit of the machine and completely remove it. Pull the belt towards the rear of the machine over the drive roller, the tensioning cylinder will retract allowing the belt to come out of the drive roller. Position the replacement belt over the in feed idler roller. Stretch the belt over the drive roller by pulling towards the rear of the machine. Again the tensioning cylinder will retract and it will be possible to start the belt over the drive roller in to its groove.

Replace all guards that were removed before restarting the machine.

Tip: It is easier to remove and install a new belt by rotating the drive roller when pulling the belt in or out of the groove.

GUARD
MOUNTING
HARDWARE

SIDE BELT
FRONT GUARD

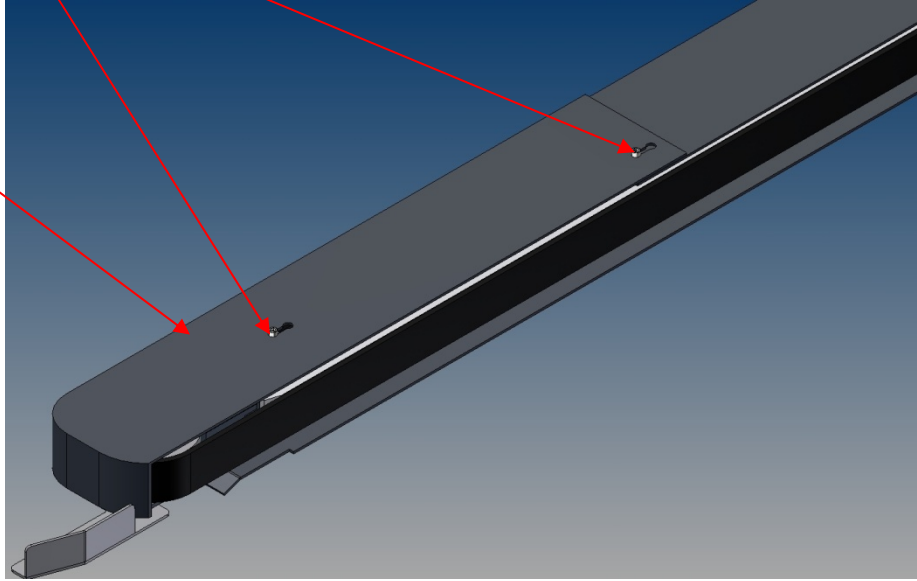

GUARD
MOUNTING
HARDWARE

SIDE BELT
REAR GUARD

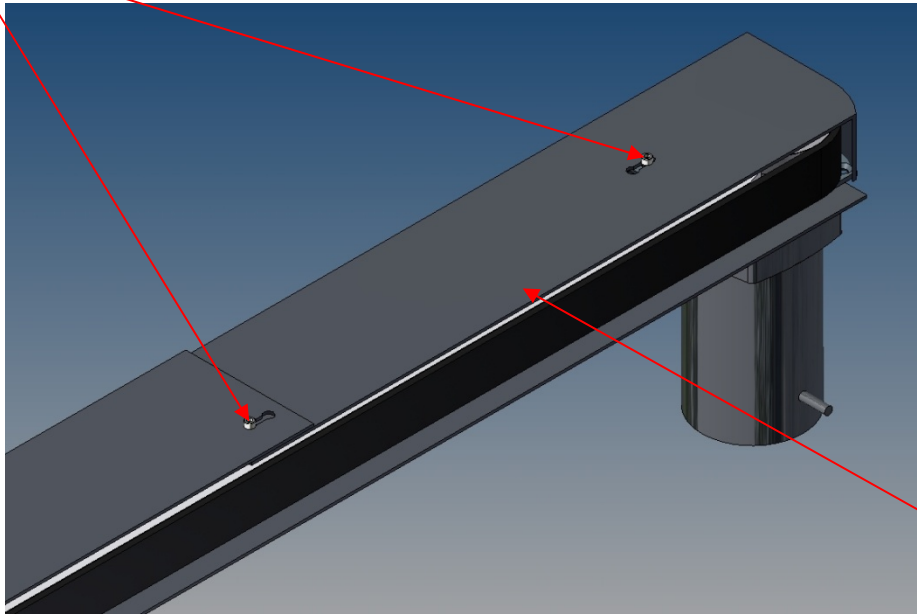

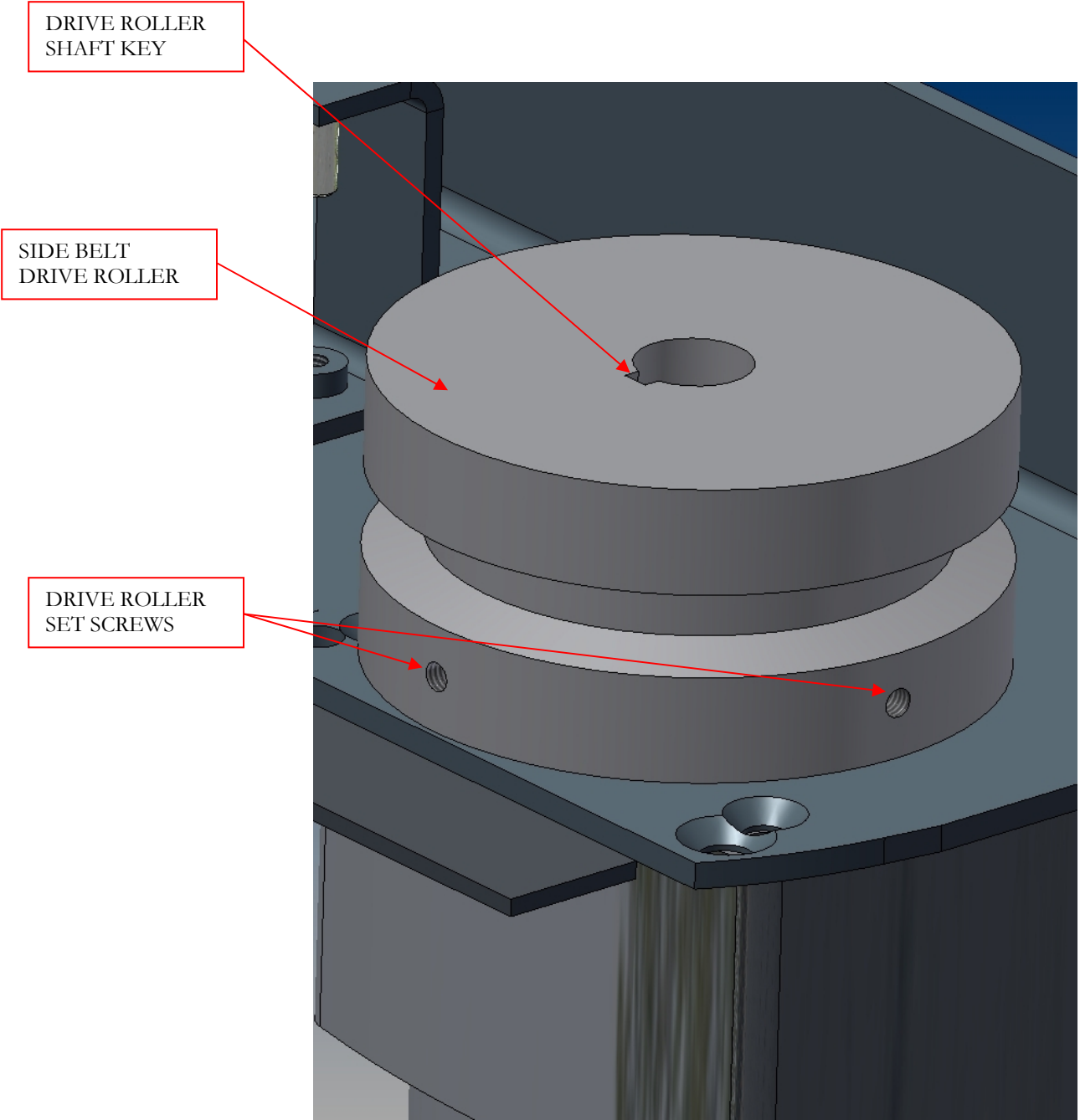

Replacing Side Belt Gear motor

First remove the side drive belt, refer to side belt replacement procedure earlier in this chapter. Remove the conduit cover from the side belt motor and disconnect the motor cable from the motor leads. Take note on how the motor is connected to the motor cable when re-connection takes place. Remove the drive roller from the motor drive shaft. Two 6mm set screws hold the driver roller in place. Note the elevation of the drive roller of the face of the gear motor, this is important when installing the drive roller to the new motor. Remove the four 1/4 - 28 fasteners securing the motor to the belt arm frame. There are socket head cap screws and flat head cap screws utilized. Do not mix them up when installing the new motor.

With the old motor removed install the new motor to the belt arm assembly. The drive roller position must be set on the shaft of the motor as previous. The centerline of the drive roller must be at the same elevation as the center of the side belt drive guide strips. Do not forget to use the key in the drive roller and the motor shaft, and make sure to tighten both set screws in the drive roller.

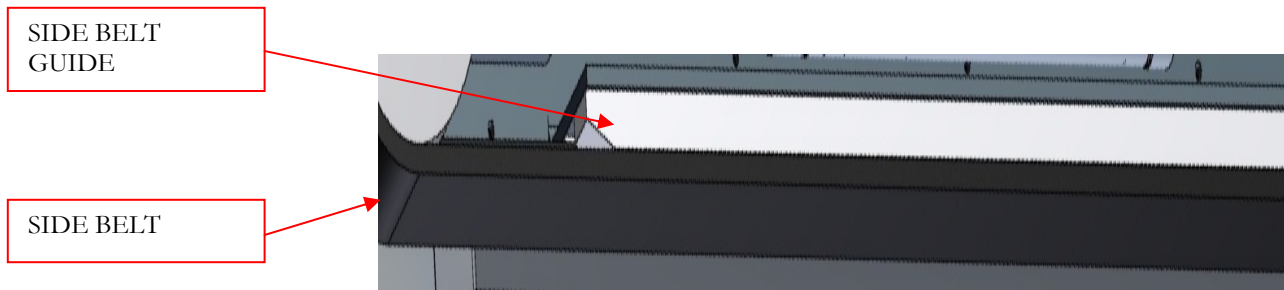

Rear Flap Folders Cylinder Replacement

To change a rear flap folder cylinder the cover must first be removed. With the cover removed it will be possible to unattach the folding arm from the rod end attached to the cylinder. Now loosen the jam nut that is securing the rod end to the cylinder shaft. Completely spin the rod end counter clockwise to remove the rod end from the cylinder. *Tip:* Record how many turns of the rod end it takes to remove it from the end of the cylinder. This will be helpful when installing the rod end to the new cylinder. Remove the hardware from the shaft that mounts the rear pivot of the cylinder. There is an upper and lower collar that centers the cylinder on the shaft. It is only necessary to remove one of the collars to slide the cylinder off the shaft. Disconnect the airline and remove the cylinder from the assembly. Remove the air filling from the old cylinder and install it on the new cylinder. Use Teflon tape or some other suitable compound to insure that there will not be an air leak. Reverse the steps previously to re-install the new cylinder. With the new cylinder installed make sure that flap folder is perfectly parallel to the top frame. If it is not simply adjust the rod end on the cylinder in or out to get the proper orientation. Make sure to tighten the jam nut against the rod end so it will not loosen over time and unthread from the cylinder shaft.

MAJOR FLAP
FOLDER
CYLINDER

MAJOR FLAP FOLDER
CYLINDER ROD END

REAR MINOR
FLAP FOLDER
GUARD

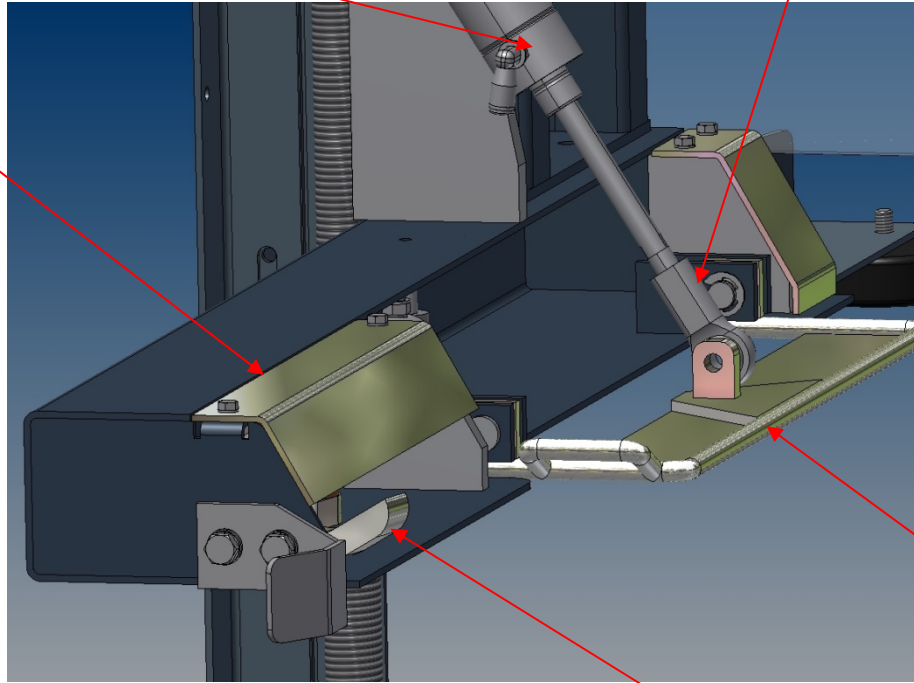

MAJORFLAP
FOLDER

REAR MINOR
FLAP FOLDER

REAR MINOR
FLAP FOLDER

FLAP FOLDER
PARALLEL TO
FRAME

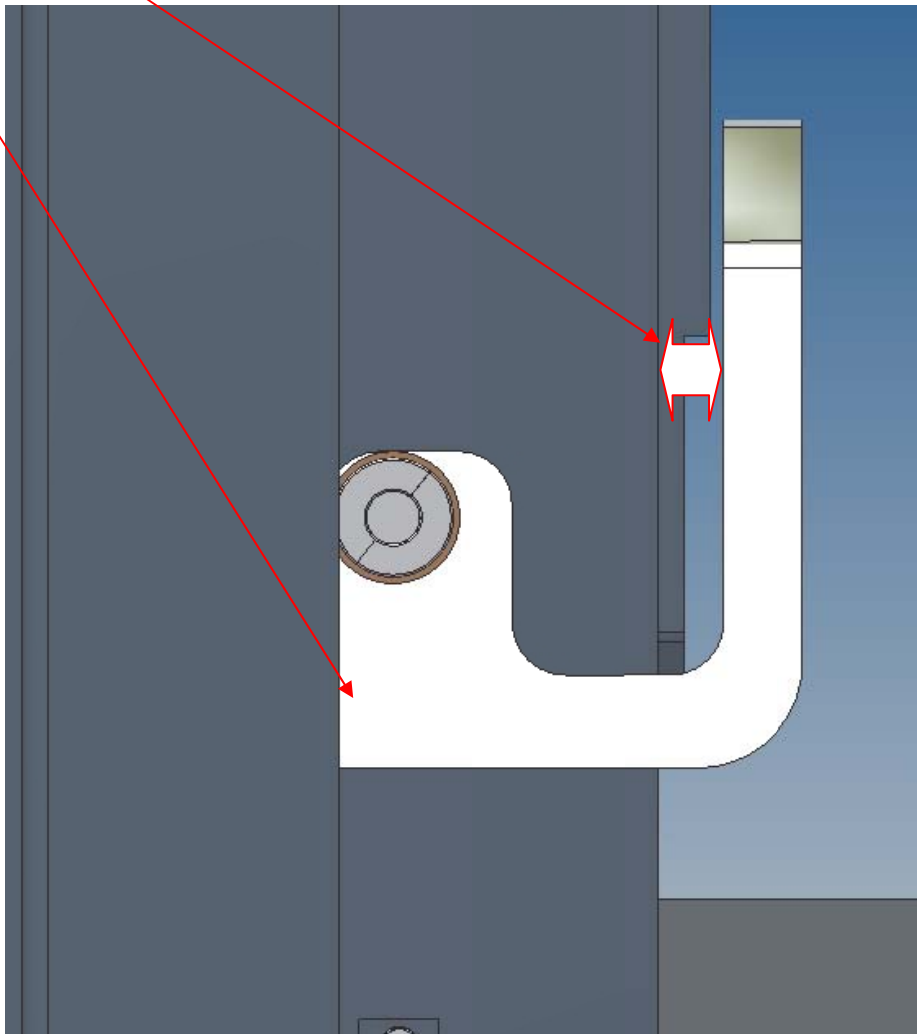

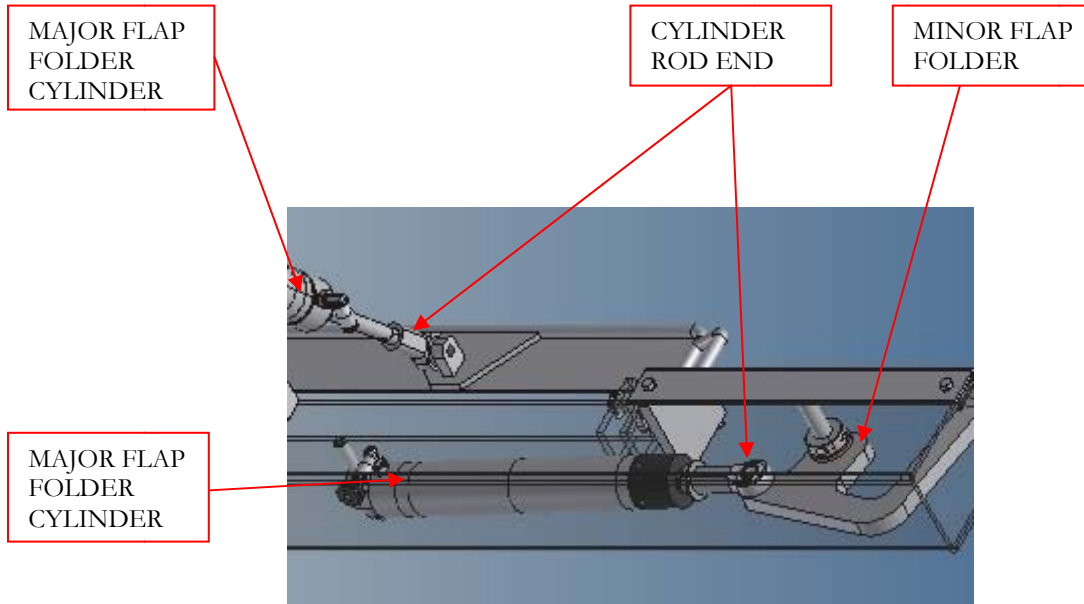

Major Flap Folder Cylinder Replacement

To replace a major flap folder cylinder remove the airlines and fittings from the air cylinder. Remove the bolt that fastens the cylinder rod end to the major flap folder. Remove the bolt that fastens the rear of the cylinder to its mounting bracket. With the cylinder removed from the machine, remove the rod end from the cylinder shaft. Loosen the jam nut first and then rotate the cylinder rod end until completely unthreads from the shaft of the cylinder. When unthreading the rod end count how many turns it takes, this will be the same number to set the rod end when installing it on the new cylinder. Install the new cylinder by reversing the previous steps. To set the position of the flap folder properly, turn the rod end until the major flap folder is perpendicular to the bottom frame of the machine. Never set the flap folders so that they over rotate past perpendicular, since this will result in box jams.

Indexing Gate Cylinder Replacement

To replace the indexing gate cylinder remove the airlines and fittings from the air cylinder. Remove the clevis from the cylinder rod, it will be necessary to remove the clevis pin from the indexing gate an cylinder rod end. Remove the mounting hardware from the bottom of the cylinder. Install the new cylinder by reversing the earlier steps. Set the height of the indexing gate when the cylinder is fully retracted via the clevis rod end. The gate must be set just low enough to allow a box to enter without interfering with it.

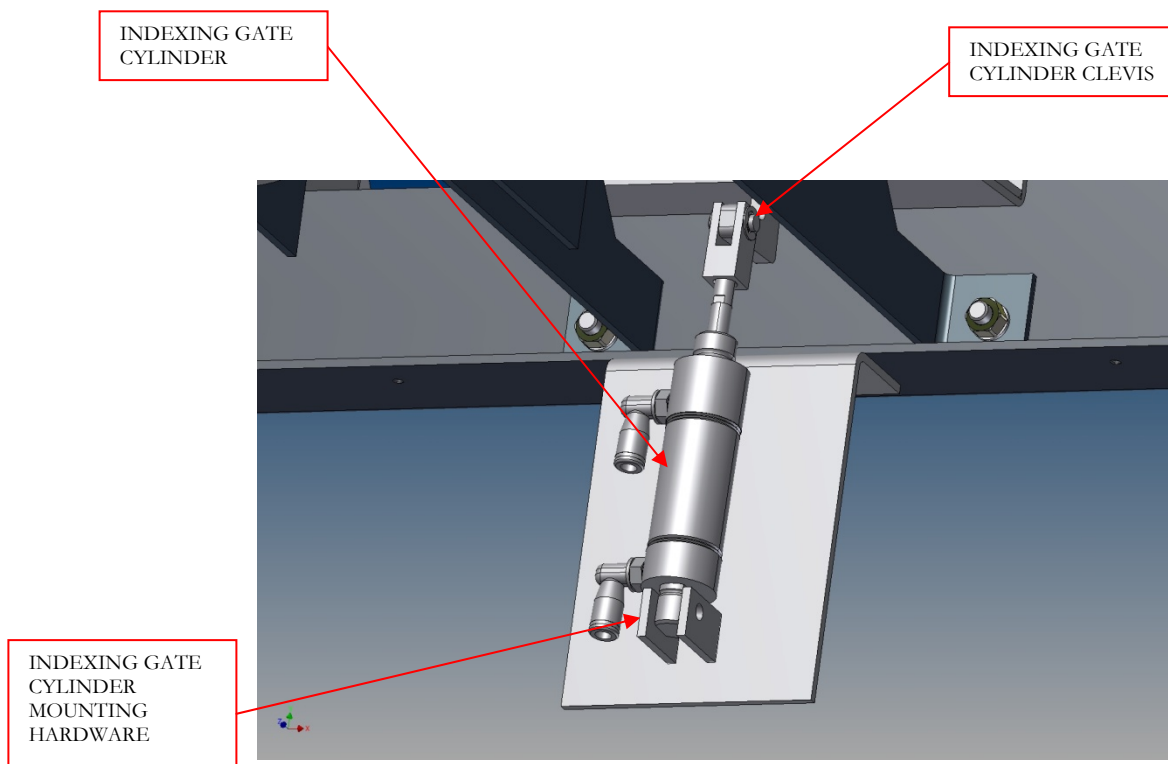

Troubleshooting:

PROBLEM	CAUSE	CORRECTIVE ACTION
Machine will not start.	Emergency stop switch(s) activated either main enclosure or remote op. station. No incoming power. Defective start pushbutton	Check that both E-stop switches are not engaged. Check machine fuses and source power. Re-place pushbutton.
Box jamming in machine.	Box is out of range of machine. Machine is not properly set for box. Tape cartridge problems. Drive belting worn.	Do not run out of spec box. Adjust per instructions. Check tape cartridge troubleshooting. Replace drive belts.
Top flaps will not fold.	Machine E-stopped. Air not present at machine. Photoelectric sensors not working Product over score lines of box. Air pressures incorrect.	Check that E-stops are not engaged. Connect machine airline. Check operation replace if needed. Repack box, training. Re-adjust to initial values.
Side belt motors won't run.	Machine E-stopped. Overload relay tripped. Drive roller not connect to motor shaft. Blown fuse.	Check that E-stops are not engaged. Reset overload check for jamming. Tighten drive roller set screws insert key. Replace fuse and check for cause.

Drive belts are slipping.	Belts are not tensioned. Belts are worn.	Check air pressure at regulator “R3”. Replace drive belts.
Rear flap does not fold down	Suppressor not set properly.	Rear flap collides with suppressor while flap is being folded downward. Check suppressor is set to width of box. If it is a manual adjustment will be necessary. Slide suppressor towards discharge end of machine by ¼” increments until flap no longer collides with suppressor. Record setting for future use.
Rear flap does not stay down after being initially folded.	Suppressor not set properly.	Rear flap pops back up after being folded. Check suppressor is set to width of box. If it is a manual adjustment will be necessary. Slide suppressor towards entrance end of machine by ¼” increments until flap is held down by the suppressor. Record setting for future use.
Rear flap does not fold down	Indexing gate is pushing up box as it is entering machine.	The indexing gate needs to be held down by the weight of the box as it enters the machine. The initial air pressure setting for the indexing gate is 25 PSI. Adjust it downward until the box is not pushed up by the indexing gate. The minimum air pressure setting is 12 PSI. If this adjustment still does not solve the issue there is a flow control located next to air cylinder which will allow the gate movement upwards to be slowed.

Warranty:

CASE SEALER, CUSTOM & SPECIAL APPLICATIONS

Little David[®] Warranty

For: All Standard Little David[®] Semi-Automatic Case Sealers.
All Standard LD-16 Series Fully Automatic Case Sealers.

All Special Application Case Sealers (Fully & Semi Automatic).

2 YEAR WARRANTY ON DRIVE MOTOR

2 YEAR WARRANTY ON GEAR MOTOR

2 YEAR WARRANTY ON GEAR REDUCER

3 YEAR WARRANTY ON TAPE CARTRIDGE

(EXCEPT FOR MOVING PARTS THAT ARE SUBJECT TO NORMAL WEAR, TEAR AND REPLACEMENT WHICH ARE WARRANTED ONLY TO BE FREE FROM DEFECTS IN MATERIAL AND WORKMANSHIP.)

1 YEAR ON PLC

1 YEAR ON SERVO DRIVE

1 YEAR ALL OTHER PARTS

Except for wear and moving parts.

*LIMITED WARRANTY – **LOVESHAW**, an *ITW* COMPANY (HEREIN AFTER "**LOVESHAW**")

WARRANTS ONLY THAT THE GOODS SOLD BY IT SHALL BE FREE FROM DEFECTS IN MATERIAL AND WORKMANSHIP, UNDER PROPER AND NORMAL USE AND MAINTENANCE,

AS FOLLOWS:

<u>DRIVE MOTOR</u> -	2 YEARS
<u>GEAR REDUCER</u> -	2 YEARS
<u>GEAR MOTOR</u> -	2 YEARS (THIS APPLIES TO SIDE BELTS ONLY)
<u>TAPE CARTRIDGE</u> -	3 YEARS (EXCEPT FOR MOVING PARTS AND PARTS WHICH ARE SUBJECT TO NORMAL WEAR, TEAR AND REPLACEMENT WHICH ARE WARRANTED ONLY TO BE FREE FROM DEFECTS IN MATERIAL AND WORKMANSHIP);
<u>PLC</u> -	1 YEAR
<u>SERVO DRIVE</u> -	1 YEAR
<u>ALL OTHER PARTS</u> -	1 YEAR (EXCEPT FOR MOVING PARTS AND PARTS, WHICH ARE SUBJECT TO NORMAL WEAR, TEAR AND REPLACEMENT WHICH ARE WARRANTED ONLY TO BE FREE FROM DEFECTS IN MATERIAL AND WORKMANSHIP).

THE WARRANTY PERIOD SHALL COMMENCE AS OF THE DATE OF DELIVERY TO THE PURCHASER. THE OBLIGATION OF **LOVESHAW** UNDER THIS WARRANTY IS STRICTLY LIMITED TO THE COST OF REPAIRING OR REPLACING, AS **LOVESHAW** MAY ELECT, ANY PART OR PARTS THAT PROVE IN **LOVESHAW'S** JUDGMENT TO HAVE BEEN DEFECTIVE IN MATERIAL OR WORKMANSHIP AT THE TIME THE GOODS WERE SHIPPED FROM **LOVESHAW'S** PLANT. ANY WARRANTY CLAIM NOT MADE IN WRITING TO **LOVESHAW** AT ITS HOME OFFICE WITHIN THE APPLICABLE WARRANTY PERIOD AND WITHIN 10 DAYS OF FAILURE WILL NOT BE VALID. THIS IS THE SOLE AND EXCLUSIVE REMEDY AVAILABLE UNDER THIS WARRANTY. UNDER NO CIRCUMSTANCES WILL **LOVESHAW** BE LIABLE FOR INCIDENTAL, SPECIAL OR CONSEQUENTIAL DAMAGES.

IF REQUESTED BY **LOVESHAW**, PURCHASER SHALL RETURN ANY DEFECTIVE PART OR PARTS TO **LOVESHAW'S** PLANT, FREIGHT PREPAID. ALL WARRANTY PART REPLACEMENT AND REPAIRS MUST BE MADE BY **LOVESHAW** OR A **LOVESHAW** DEALER AUTHORIZED TO HANDLE THE GOODS COVERED BY THIS WARRANTY. ANY OUTSIDE WORK OR ALTERATIONS DONE WITHOUT **LOVESHAW'S** PRIOR WRITTEN APPROVAL WILL RENDER THIS WARRANTY VOID. **LOVESHAW** an **ITW** COMPANY WILL NOT ASSUME ANY EXPENSE OR LIABILITY FOR ANY REPAIRS MADE TO ITS GOODS OUTSIDE ITS WORKS WITHOUT ITS PRIOR WRITTEN CONSENT. THIS WARRANTY SHALL NOT APPLY TO ANY ITEM THAT HAS NOT BEEN USED, OPERATED, AND MAINTAINED IN ACCORDANCE WITH **LOVESHAW'S** RECOMMENDED PROCEDURES. **LOVESHAW** SHALL HAVE NO LIABILITY WHATSOEVER WHERE THE GOODS HAVE BEEN ALTERED, MISUSED, ABUSED OR INVOLVED IN AN ACCIDENT.

NO PERSON IS AUTHORIZED TO MAKE ANY WARRANTY OR TO CREATE ANY LIABILITY BINDING UPON **LOVESHAW**, WHICH IS NOT STATED IN THIS WARRANTY. THIS WARRANTY IS EXPRESSLY IN LIEU OF ALL OTHER WARRANTIES OF ANY KIND, EXPRESSED OR IMPLIED, WHICH ARE HEREBY EXCLUDED. IN PARTICULAR, THE IMPLIED WARRANTY OF MERCHANTABILITY, AS WELL AS THE IMPLIED WARRANTY OF FITNESS FOR A PARTICULAR PURPOSE ARE HEREBY EXCLUDED.

LOVESHAW

an *ITW* Company
2206 Easton Turnpike, South Canaan, PA 18459
570.937.4921 - 800.572.3434 - FAX 570.937.3229

Chapter

10

ASSEMBLY DRAWINGS AND SCHEMATICS

REVISION HISTORY			
REV	DESCRIPTION	DATE	BY
A	RELEASED	8/19/2011	BJF

Parts List			
ITEM	QTY	PART NUMBER	DESCRIPTION
1	1	LD25-0058-6	PRODUCT SUPPORT
2	1	LD25-0098-4	SLIDE STRIP, FRONT
3	1	LD25-0093-4	SLIDE STRIP, REAR
4	1	LD25-0052-6	FRAME WELDMENT
5	1	LD25-0109-4	PHOTOEYE BRACKET
6	1	LD25-0110-4	REFLECTOR BRACKET
7	1	LD25-0061-6	UPRIGHT ASSEMBLY
8	1	LD25-0111-3	PHOTOEYE BRACKET, UPRIGHT
9	6	LD25-0064-4	STANDOFF, SAFETY GATES
10	2	LD25-0121-4	INDICATOR RAIL
11	2	LD25-0113-4	CARTRIDGE SPACER, BOTTOM
12	4	FHNMIP	HEX NUT M10
13	8	FLWMIP	LOCK WASHER M10
14	4	FSHM035P88	SHCS M10x30
15	14	FFHMF012P10	FHCS M5 X 0.8 X 12 LG.
16	12	FLWMHP	LOCK WASHER M8
17	6	FHHMH016P10	HHCS M8 X 16
18	4	FLWMGP	LOCK WASHER M6
19	6	FHHMG012P10	HHCS M8 X 12
20	6	FHHMH020P10	HHCS M8 X 20
21	6	FHFNHMP	HEX NUT, M8
22	2	FFWMP	FLAT WASHER M6
23	4	FFWMFP	FLAT WASHER M5
24	4	FHFNMFPP	HEX NUT M5
25	4	FHHMF016P10	HEX HEAD M5 x 16
26	3	LD25-0125-3	SPACER, ELECTRICAL BOX
27	2	LD25-0147-4	MAST SUPPORT
28	4	FHHM030P88	HHCS M10 X 1.5 X 30 LG.

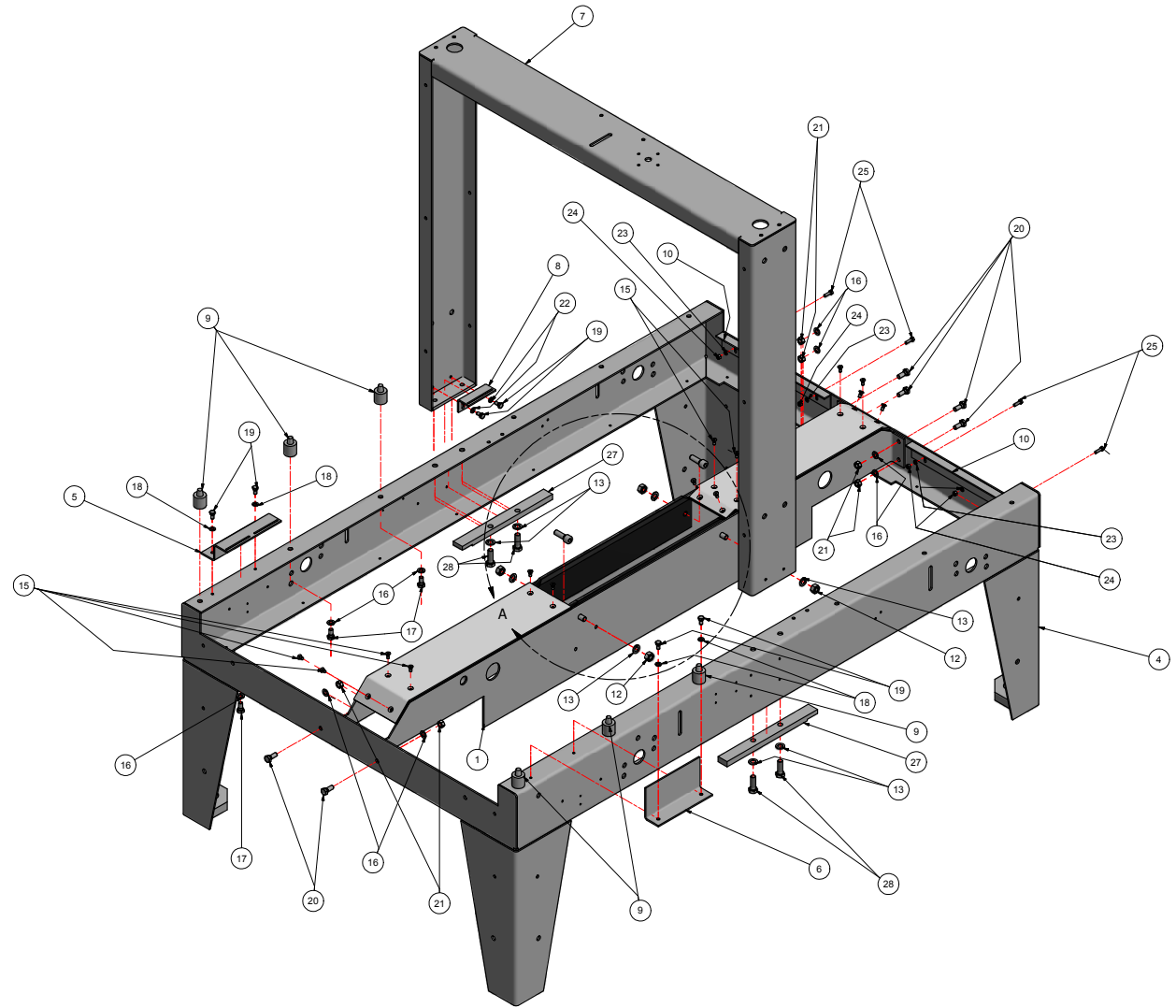

DETAIL A
SCALE 1/6

MATL	PART#	CAD FILE	FRAME ASSY	TOLERANCES UNLESS OTHERWISE NOTED:	LOVESHAW an ITW Company RT. 296 SOUTH CANAAN, PA.
BT	STD	PLDT DATE	DRAWN DATE	8/19/2011	
STAINLESS - NO FINISH				DO NOT SCALE PRINT	X = ±.000 INCH XXX = ±.015 XXXX = ±.005 X = ±1.0mm METRIC XX = ±.0mm XXX = ±.1mm
THIS DRAWING AND SUBJECT MATTER THEREON IS THE EXCLUSIVE PROPERTY OF LOVESHAW AND IS TO BE TREATED AS CONFIDENTIAL. ANY REPRODUCTION OR DISSEMINATION OF THIS DRAWING OR SUBJECT MATTER SHALL BE PROHIBITED UNLESS AUTHORIZED BY LOVESHAW. THIS DRAWING IS TO BE RETURNED TO LOVESHAW UPON REQUEST.				MACH FURNISH DRAWN BRYCEF APPROVED	TITLE FRAME ASSEMBLY LD24 DWG NO SCALE CHECKED MATERIAL

REVISION HISTORY			
REV	DESCRIPTION	DATE	BY
A	RELEASED	10/10/2011	BJF

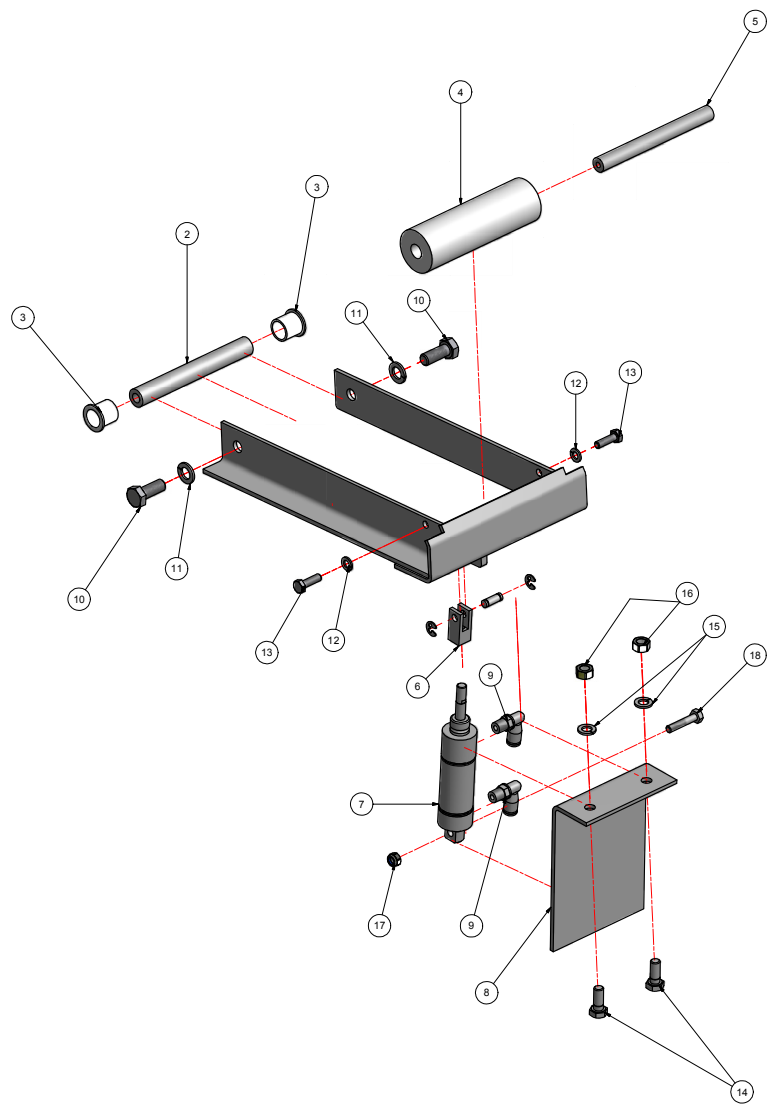

Parts List			
ITEM	QTY	PART NUMBER	DESCRIPTION
1	1	LD25-0035-6	GATE WELDMENT
2	1	LD25-0036-4	SHAFT - GATE
3	2	PSC301224	BUSHING
4	1	LD25-0037-4	GATE ROLLER
5	1	LD25-0038-4	GATE ROLLER SHAFT
6	1	N400-226	CLEVIS & PIN
7	1	N401-353	CYLINDER
8	1	LD25-0039-4	CYLINDER BRACKET
9	2	N400-25	1/4\"/>
10	2	FHHMI025P88	HHCS M10 X 25
11	2	FLWMIP	LOCK WASHER M10
12	2	FLWMGP	LOCK WASHER M6
13	2	FHHMG020P10	HHCS M6 X 20
14	2	FHHMH020P10	HHCS M8 X 20
15	2	FLWMHP	LOCK WASHER M8
16	2	FHFNMHP	HEX NUT, M8
17	1	FNLNMGP	NYLOCK NUT M6
18	1	FHHMG030P10	HHCS M6 X 30

MATL	PART#	CAD FILE	IGA-LD24.idw	TOLERANCES UNLESS OTHERWISE NOTED:	LOVESHAW an JTW Company RT. 296, SOUTH CANAAN, PA.
BT ST.	STD	PLOT DATE	10/10/2011	X = ±.000 NCH .XX = ±.015 XXX = ±.005 ANGLES 1/2°	
STAINLESS - NO FINISH		DO NOT SCALE PRINT		X = ±1.0mm METRIC .XX = ±.3mm XXX = ±.1mm F	INFEED GATE ASSEMBLY
<small>THIS DRAWING AND SUBJECT MATTER THEREON IS THE EXCLUSIVE PROPERTY OF LOVESHAW AND SHALL BE TREATED BY YOU AS CONFIDENTIAL, PROPRIETARY INFORMATION. THE DRAWING OR SUBJECT MATTER THEREOF SHALL NOT BE REPRODUCED OTHER THAN FOR YOUR OWN USE OR TO BE DISCLOSED TO OTHERS WITHOUT THE EXPRESS WRITTEN CONSENT OF LOVESHAW AND SHALL BE RETURNED TO LOVESHAW UPON REQUEST.</small>				MACH F FINISH	DWG NO IGA-LD24 SCALE MATERIAL DRAWN BRYCEF CHECKED APPROVED
				FRACTIONS 1/64	

REVISION HISTORY			
REV	DESCRIPTION	DATE	BY
A	RELEASED	10/10/2011	BJF

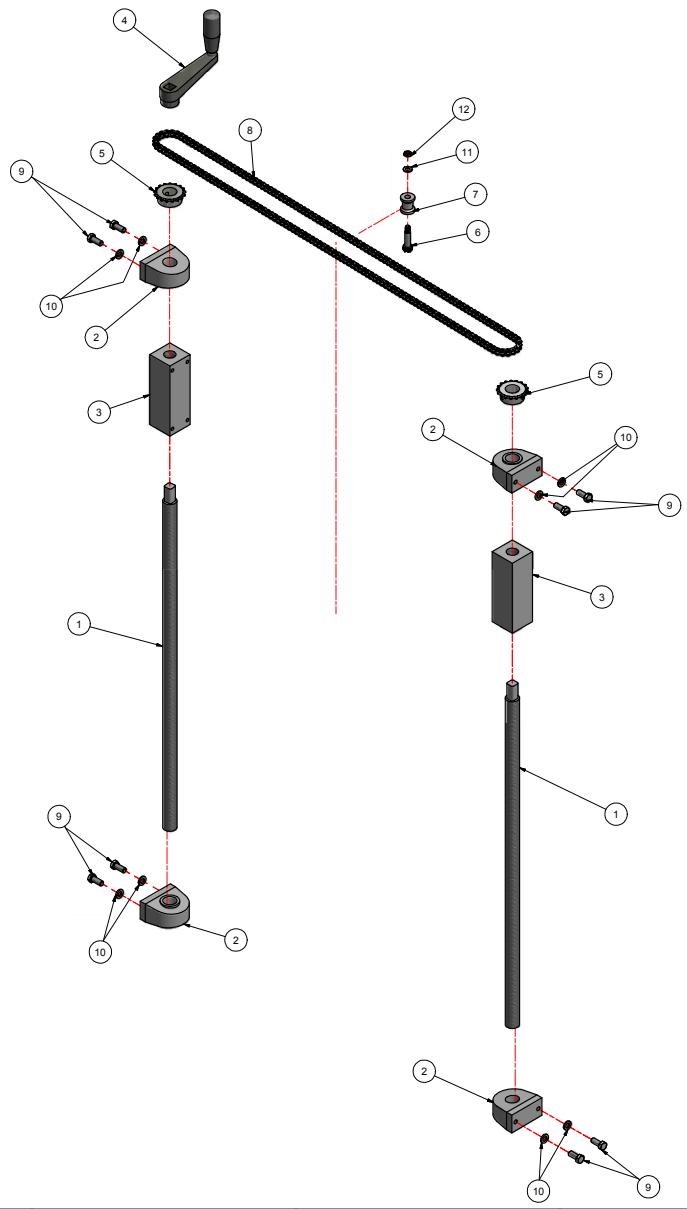

Parts List			
ITEM	QTY	PART NUMBER	DESCRIPTION
1	2	LD25-0043-4	SCREW, HEAD RAISING
2	4	BRG-2013	1" TAPPED BASE BEARING
3	2	LD25-0044-4	LEAD NUT
4	1	HC-1023	CRANK HANDLE
5	2	LD3SB2-2026	SPROCKET
6	1	SPH-1476	M10 x 30 SHOULDER BOLT
7	1	LD25-0112-3	CHAIN TENSIONER
8	1	HC101	#35 ROLLER CHAIN
9	8	FHHSJ088P05	HHCS 3/8-16 X 7/8 LG.
10	8	FLWSFP	LOCK WASHER 3/8
11	1	FFWMHP	FLAT WASHER M8
12	1	FHJNMHP	HEX JAM NUT, M8, PLATED

MATL	PART#	CAD FILE	HLA-LD24.idw	TOLERANCES UNLESS OTHERWISE NOTED:	LOVESHAW an ITW Company RT. 296, SOUTH CANAAN, PA.
BT ST.	STD	PLOT DATE	10/10/2011	X=.0005 HCH .XX ±.015 ANANGLES ±1° XXX ±.005 X=.11mm METRIC .XX ±.3mm .XXX ±.1mm	
STAINLESS - NO FINISH		DO NOT SCALE PRINT		TITLE HEAD LIFTING ASSY . LD24	
THIS DRAWING AND SUBJECT MATTER THEREON IS THE EXCLUSIVE PROPERTY OF LOVESHAW AND IS TO BE TREATED AS YOUR CONFIDENTIAL PROPRIETARY INFORMATION. THE DRAWING OR SUBJECT MATTER THEREON SHALL NOT BE REPRODUCED OTHER THAN FOR YOUR OWN USE OR TO BE DISCLOSED TO OTHERS WITHOUT THE EXPRESS WRITTEN CONSENT OF LOVESHAW AND SHALL BE RETURNED TO LOVESHAW UPON REQUEST.				DWG NO HLA-LD24	
				MATERIAL BRYCEF	
				SCALE 1/64	
				CHECKED BRYCEF	
				APPROVED	

REVISION HISTORY			
REV	DESCRIPTION	DATE	BY
A	RELEASED	10/10/2011	BJF

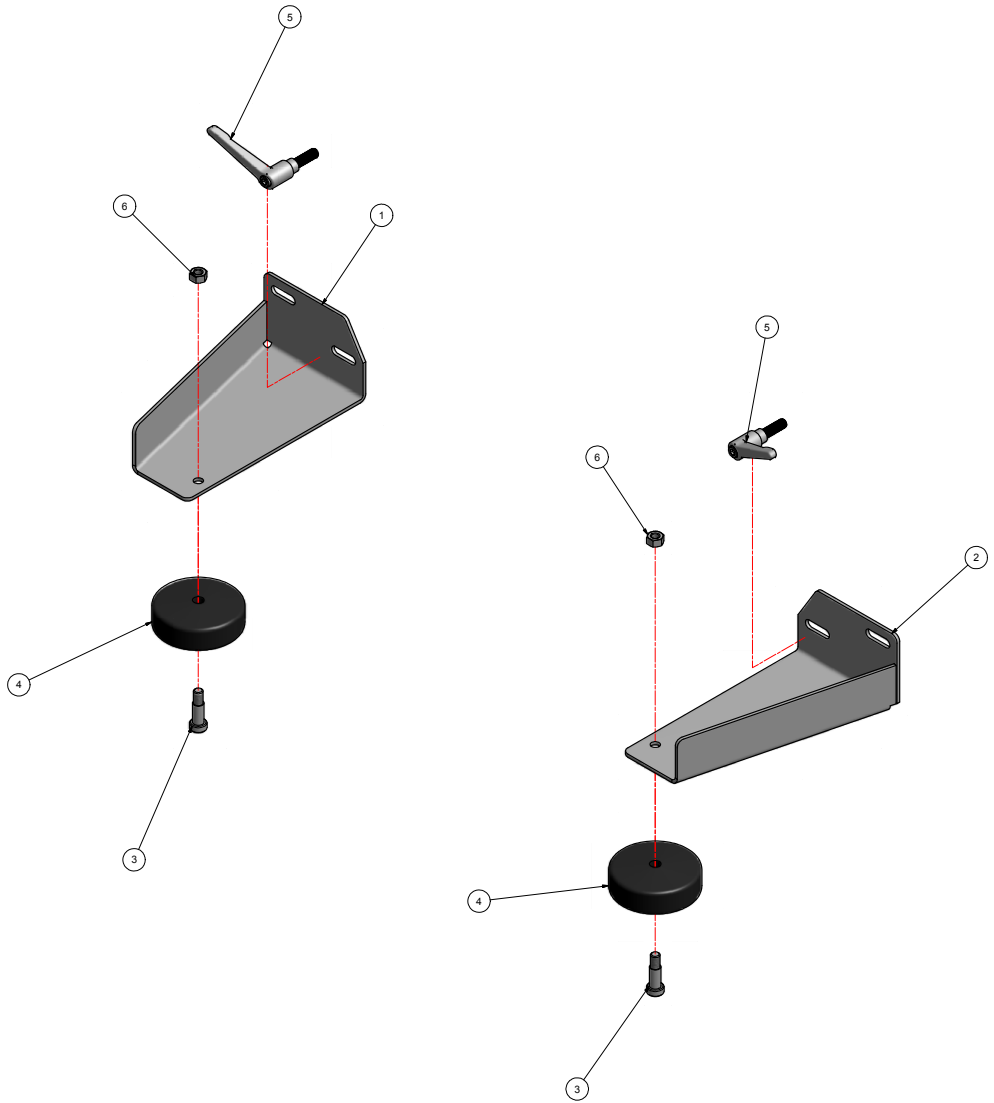

Parts List			
ITEM	QTY	PART NUMBER	DESCRIPTION
1	1	LD25-0051R-6	SQUEEZER ARM, RIGHT
2	1	LD25-0051L-6	SQUEEZER ARM, LEFT
3	2	SPH-1437	BOLT, SHOULDER
4	2	LDW-0093-3	SQUEEZER WHEEL
5	1	LD25-0118-4	SQUEEZER WHEEL
6	2	FHFNSHP	HEX NUT 5/16-18

MATL	PART#	CAD FILE	TSA-LD24.idw	TOLERANCES UNLESS OTHERWISE NOTED:	LOVESHAW an ITW Company RT. 296, SOUTH CANAAN, PA.
	STD	PLOT DATE	10/10/2011	X=.0005 HCH .XX ±.015 ANGLSES ±1/2° XXX ±.005	
BT. ST.		DRAWN DATE	10/10/2011	X ±.11mm METRIC .XX ±.3mm XXX ±.1mm	TITLE
STAINLESS - NO FINISH		DO NOT SCALE PRINT			TOP SQUEEZER ASSY.
<small>THIS DRAWING AND SUBJECT MATTER THEREON IS THE EXCLUSIVE PROPERTY OF LOVESHAW AND SHALL BE TREATED AS CONFIDENTIAL. ANY REPRODUCTION OR DISSEMINATION OF THIS DRAWING OR SUBJECT MATTER THEREON SHALL BE PROHIBITED UNLESS OTHERWISE IN WRITING BY LOVESHAW. THIS DRAWING IS THE PROPERTY OF LOVESHAW AND SHALL BE RETURNED TO LOVESHAW UPON REQUEST.</small>				MACH FRESH DRAWN BRYCEF APPROVED	SCALE CHECKED APPROVED
				FRACTIONS 1/64	

REVISION HISTORY			
REV	DESCRIPTION	DATE	BY
A	RELEASED	10/5/2011	BJF

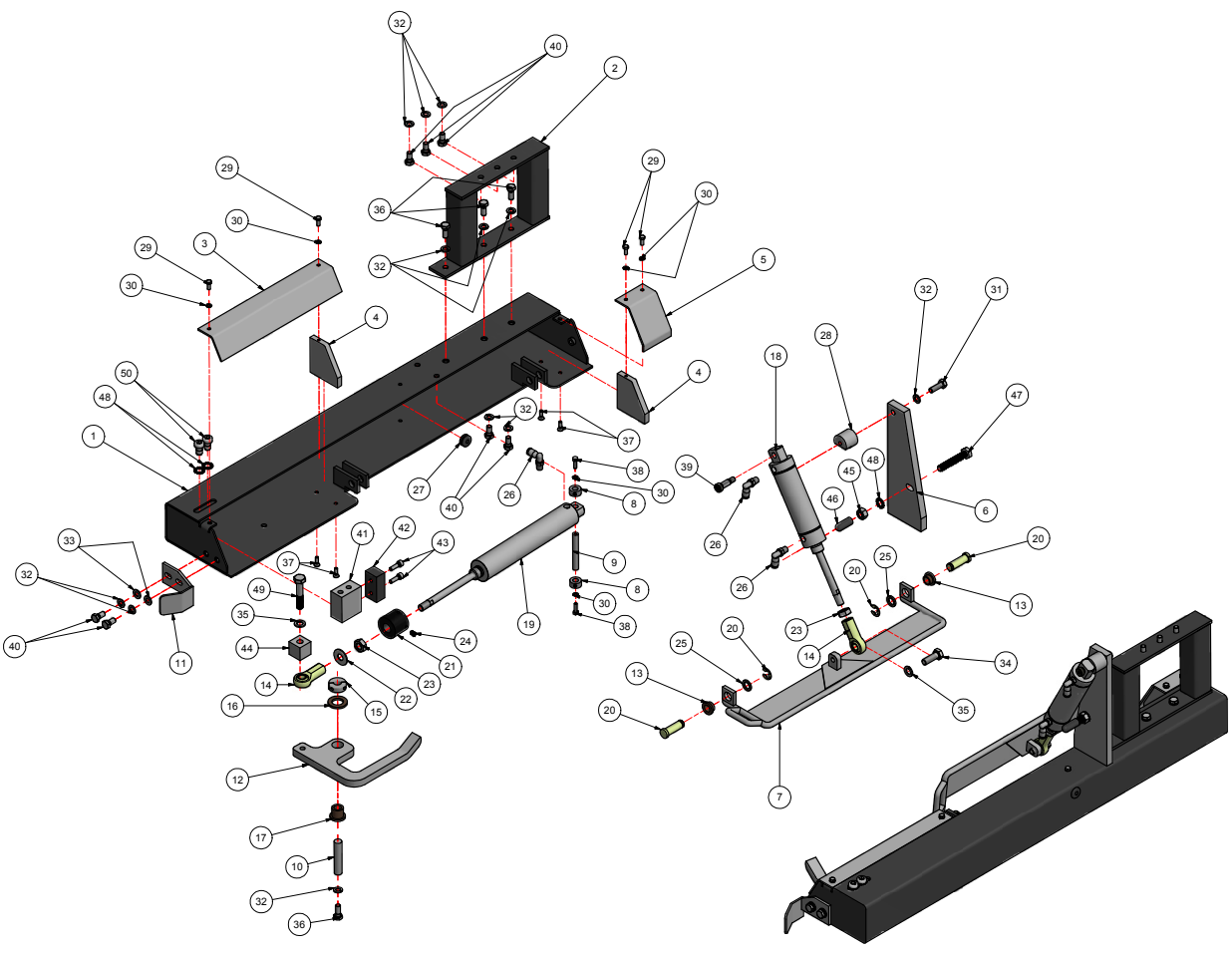

Parts List			
ITEM	QTY	PART NUMBER	DESCRIPTION
1	1	LD25-0001L-6	FOLDER HOUSING, LEFT
2	2	LD25-0008-5	FOLDER ARM MOUNT
3	2	LD25-0016-4	FRONT COVER
4	4	LD25-0018-4	SUPPORT BLOCK
5	2	LD25-0015-5	REAR COVER
6	2	LD25-0007-4	CYLINDER MOUNT, TALL
7	1	LD25-0022L-6	MAJOR FOLDER, LEFT
8	4	SC37	3/8 COLLAR
9	2	LD25-0023-3	CYLINDER PIVOT
10	2	LD25-0025-3	PIVOT SHAFT FOLDER
11	1	LD25-0028L-4	BOX GUIDE, LEFT
12	1	LD25-0026L-5	MINOR FOLDER, LEFT
13	4	BSG-1120	1/2" FLANGE BUSHING
14	4	SPH-1450	SPHERICAL ROD END
15	2	SPC-1011	1/2" SPLIT COLLAR
16	2	SPH-1451	3/4" BRONZE WASHER
17	2	BSG-1119	1/2" FLANGE BUSHING
18	2	N401-355	1 1/2" X 2 3/4" CYLINDER
19	1	N401-356	1 1/2" x 4" CYLINDER
20	4	CLP-1020	1/2" CLEVIS PIN
21	2	LD25-0114-3	CYLINDER STOP
22	2	FFWSGP	7/16" FLAT WASHER
23	4	FHJNSMP	HEX JAM NUT 7/16-20
24	2	SPH-1479	M6 SOFT POINT SET SCREW
25	4	SPH-1480	1/2" BRONZE WASHER
26	6	N400-25	1/4" X 1/4 NPT FITTING
27	2	CPM75-041-0	GROMMET
28	2	LD25-0124-3	CYLINDER MOUNT
29	8	FHHMF012P10	HHCS M5 X 12
30	12	FLWMFP	LOCK WASHER M5
31	1	FHHMH025P10	HHCS M8 X 25
32	24	FLWMHP	LOCK WASHER M8
33	4	FFWMHP	FLAT WASHER M8
34	2	FHHMI030P88	HHCS M10 X 1.5 X 30
35	4	FLWMIP	LOCK WASHER M10
36	8	FHHMH020P10	HHCS M8 X 20
37	8	FFHMF016P10	FHCS M5 X 16
38	4	FHHMF016P10	HEX HEAD M5 X 16
39	2	FSBSH075B08	SHOULDER BOLT 3/8"
40	15	FHHMH016P10	HHCS M8 X 16
41	2	LD25-0144-4	BUMPER MOUNT
42	2	LD25-0145-3	BUMPER
43	4	FSHMG020P10	SHCS M8 X 20
44	2	LD25-0146-3	BUMPER BLOCK
45	2	FHFNMIP	HEX NUT M10
46	2	SPH-1560	THREAD PROTECTOR
47	2	SPH-1561	M10 X 55 (FULL THREAD)
48	6	FETLWMIP	M10 EXT. LOCK WASHER
49	2	FHHMI055P88	HHB M10 X 55
50	4	FSHMI016P88	SHCS M10 X 16

MATL	PART#	CAD FILE	TOP FOLDING ASSY	FINISHES UNLESS OTHERWISE NOTED:	LOVESHAW an JTW Company RT. 286, SOUTH CANAAN, PA.
BT ST	STD	PLOT DATE	10/5/2011	DRAWN DATE	
STAINLESS - NO FINISH		DO NOT SCALE PRINT		X = 1/16 IN XX = 1/8 IN XXX = 1/4 IN ANGLE = 1/2°	TITLE: TOP FOLDER ASSEMBLY DWG NO: TOP FOLDING ASSY MATERIAL: STAINLESS FINISH: NO FINISH MACH: 303 FRACTIONS: 1/64
THIS DRAWING AND SUBJECT MATTER THEREON IS THE EXCLUSIVE PROPERTY OF LOVESHAW AND SHOULD BE TREATED AS SUCH. ANY REPRODUCTION, REUSE, OR DISSEMINATION OF THIS DRAWING OR SUBJECT MATTER THEREON SHALL BE PROHIBITED UNLESS EXPRESSLY AUTHORIZED BY LOVESHAW. ANY REPRODUCTION OR DISSEMINATION OF THIS DRAWING OR SUBJECT MATTER THEREON WITHOUT THE EXPRESS WRITTEN CONSENT OF LOVESHAW WILL BE RETURNED TO LOVESHAW WITH NO FURTHER REQUEST.				SCALE: AS SHOWN CHECKED: BRYCEF APPROVED: BRYCEF	

4

3

2

1

REVISION HISTORY			
REV	DESCRIPTION	DATE	BY
A	RELEASED	9/19/2011	BJF

Parts List			
ITEM	QTY	PART NUMBER	DESCRIPTION
1	1	LD25-0086-4	LEAD SCREW FRONT
2	1	LD25-0087-4	LEAD SCREW HANDLE
3	4	LD3SB2-2025	BEARING BLOCK
4	4	LD16SB-3399G-3	SPACER
5	2	LD16SB-3397A-4	LEAD NUT LEFT
6	2	LD16SB-3398A-4	LEAD NUT RIGHT
7	2	LD3SB2-2026	SPROCKET
8	1	.PFF-HANDLE	CRANK HANDLE
9	1	HC101	#35 ROLLER CHAIN
10	2	PSC22247-3	CHAIN IDLER ROLLER
11	2	PSC22248-3	SHAFT, CHAIN IDLER ROLLER
12	2	FHHMH025P10	HHCS M8 X 25
13	8	FLWMHP	LOCK WASHER M8
14	8	FHFNMHP	HEX NUT, M8
15	8	FHHMH020P10	HHCS M8 X 20
16	2	FFWMHP	FLAT WASHER M8
17	4	FHHMI060P88	HHCS M10 X 60 LG.
18	4	FFWMIP	FLAT WASHER M10
19	4	FLWMIP	LOCK WASHER M10

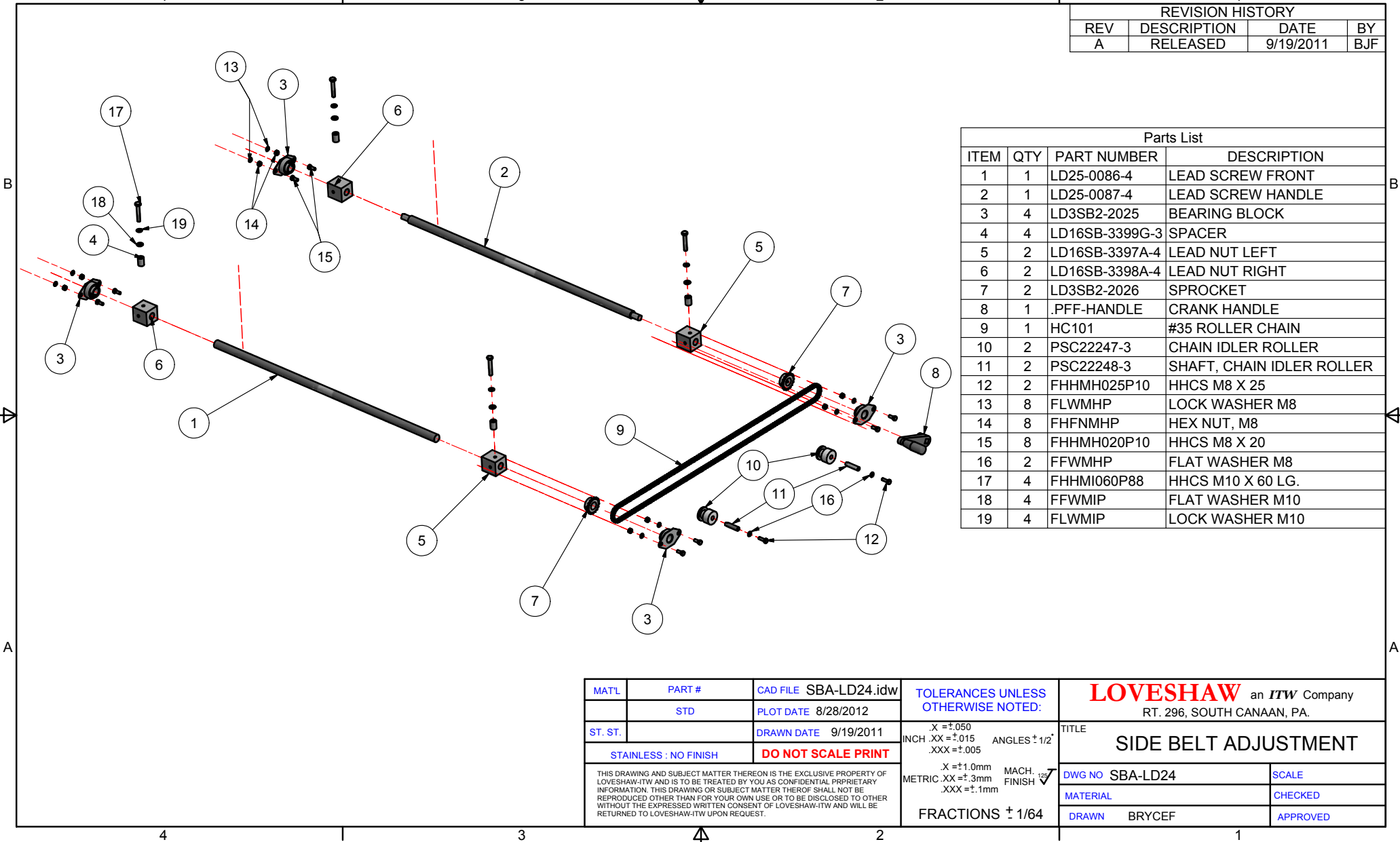

MATL	PART #	CAD FILE SBA-LD24.idw	TOLERANCES UNLESS OTHERWISE NOTED:	LOVESHAW an <i>ITW</i> Company RT. 296, SOUTH CANAAN, PA.	
ST. ST.	STD	PLOT DATE 8/28/2012	X = ±.050 INCH .XX = ±.015 ANGLES ± 1/2° .XXX = ±.005	TITLE	
		DRAWN DATE 9/19/2011		SIDE BELT ADJUSTMENT	
	STAINLESS : NO FINISH	DO NOT SCALE PRINT	X = ±1.0mm MACH. FINISH ✓ METRIC .XX = ±.3mm .XXX = ±.1mm	DWG NO SBA-LD24	SCALE
THIS DRAWING AND SUBJECT MATTER THEREON IS THE EXCLUSIVE PROPERTY OF LOVESHAW-ITW AND IS TO BE TREATED BY YOU AS CONFIDENTIAL PROPRIETARY INFORMATION. THIS DRAWING OR SUBJECT MATTER THEREOF SHALL NOT BE REPRODUCED OTHER THAN FOR YOUR OWN USE OR TO BE DISCLOSED TO OTHER WITHOUT THE EXPRESSED WRITTEN CONSENT OF LOVESHAW-ITW AND WILL BE RETURNED TO LOVESHAW-ITW UPON REQUEST.				FRACTIONS ± 1/64	MATERIAL
				DRAWN BRYCEF	APPROVED

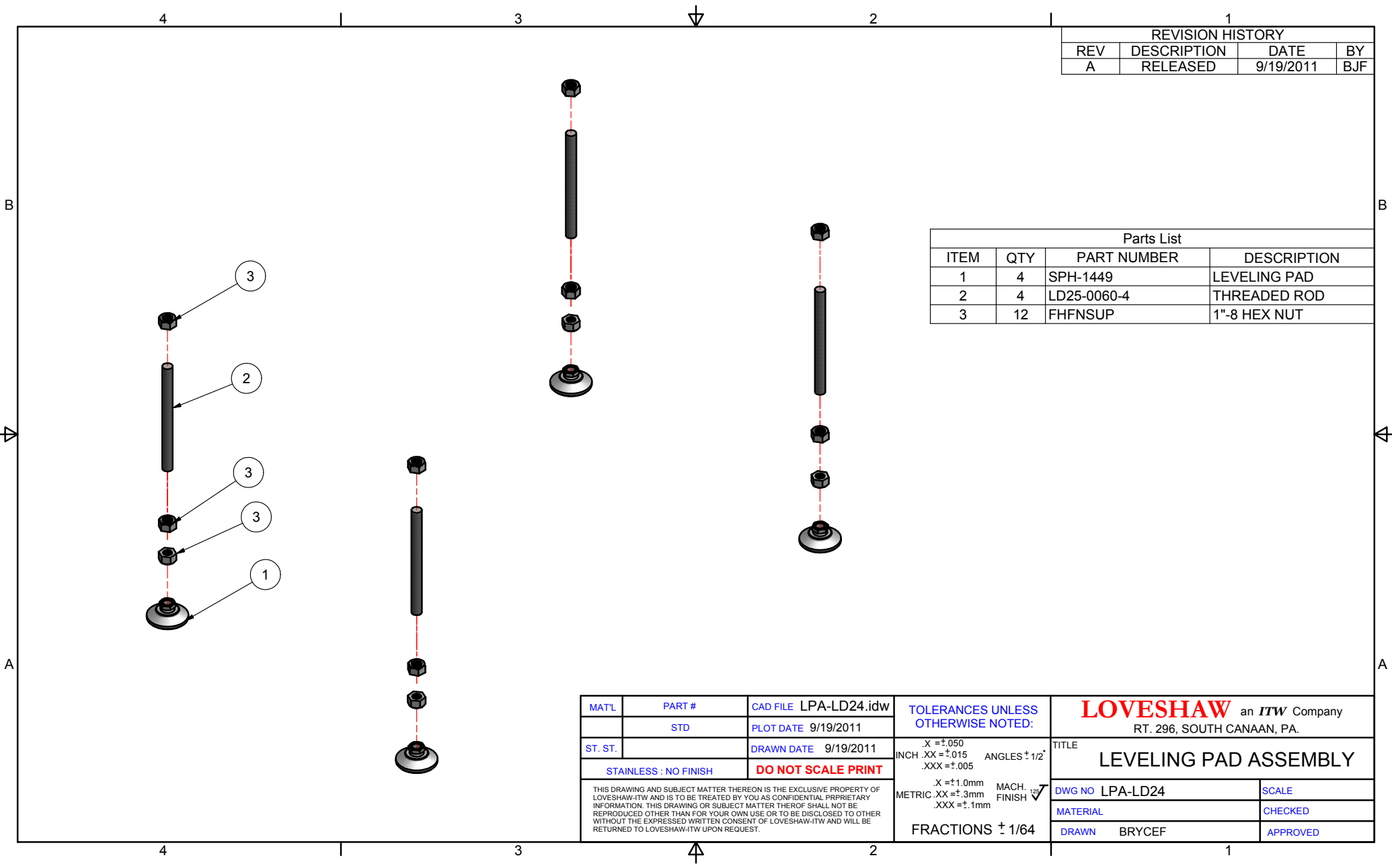

REVISION HISTORY			
REV	DESCRIPTION	DATE	BY
A	RELEASED	9/19/2011	BJF

Parts List			
ITEM	QTY	PART NUMBER	DESCRIPTION
1	4	SPH-1449	LEVELING PAD
2	4	LD25-0060-4	THREADED ROD
3	12	FHFNSUP	1"-8 HEX NUT

MATL	PART #	CAD FILE LPA-LD24.idw	TOLERANCES UNLESS OTHERWISE NOTED: X = ±.050 INCH .XX = ±.015 ANGLES ± 1/2° .XXX = ±.005 X = ±1.0mm MACH. FINISH ✓ METRIC .XX = ±.3mm .XXX = ±.1mm FRACTIONS ± 1/64	LOVESHAW an <i>ITW</i> Company RT. 296, SOUTH CANAAN, PA.	
ST. ST.	STD	PLOT DATE 9/19/2011		TITLE LEVELING PAD ASSEMBLY	
STAINLESS : NO FINISH		DO NOT SCALE PRINT	DRAWN LPA-LD24		SCALE
THIS DRAWING AND SUBJECT MATTER THEREON IS THE EXCLUSIVE PROPERTY OF LOVESHAW-ITW AND IS TO BE TREATED BY YOU AS CONFIDENTIAL PROPRIETARY INFORMATION. THIS DRAWING OR SUBJECT MATTER THEREOF SHALL NOT BE REPRODUCED OTHER THAN FOR YOUR OWN USE OR TO BE DISCLOSED TO OTHER WITHOUT THE EXPRESSED WRITTEN CONSENT OF LOVESHAW-ITW AND WILL BE RETURNED TO LOVESHAW-ITW UPON REQUEST.			MATERIAL		CHECKED
			DRAWN BRYCEF		APPROVED

REVISION HISTORY			
REV	DESCRIPTION	DATE	BY
A	RELEASED	10/11/2011	BJF

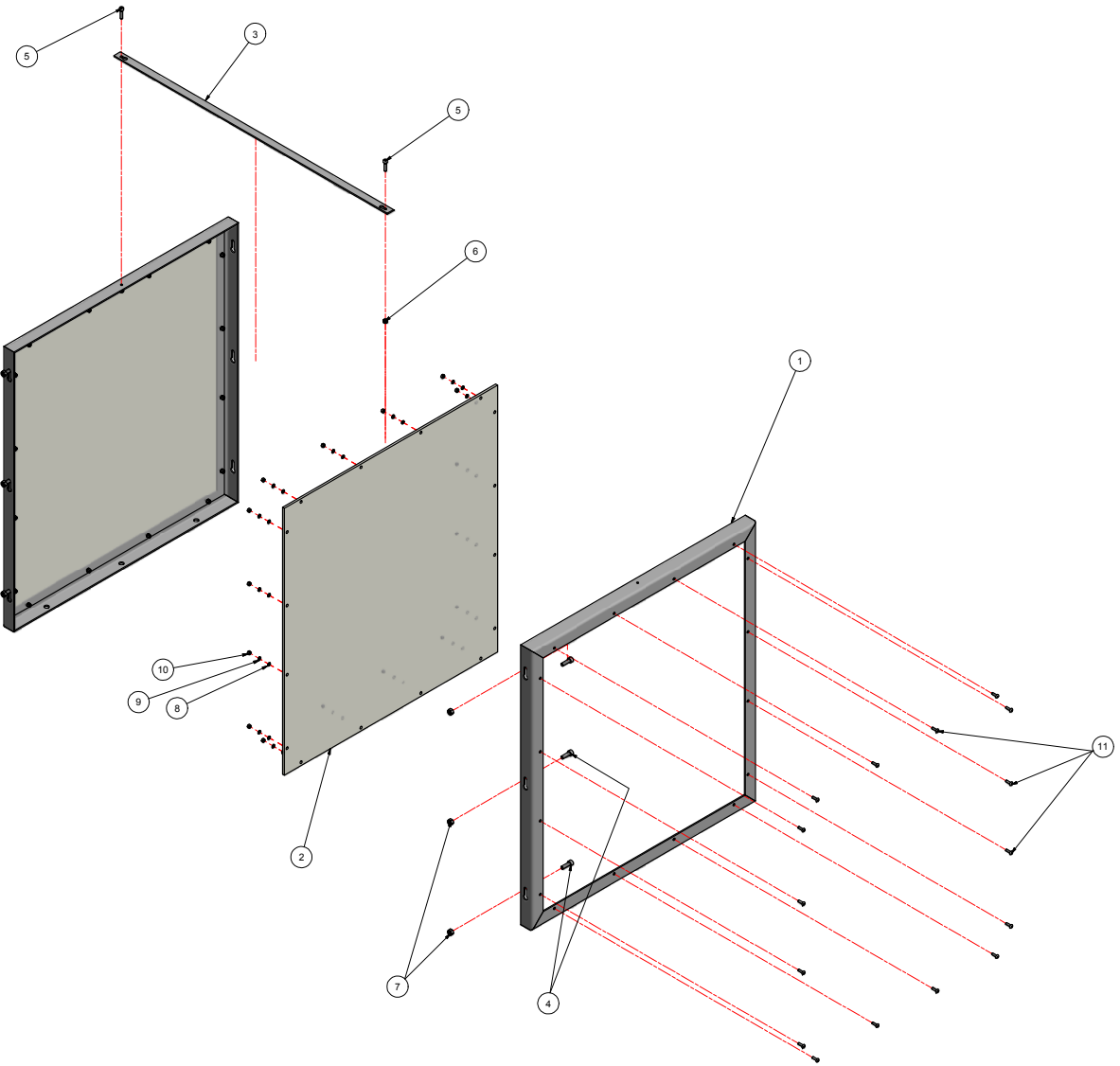

Parts List			
ITEM	QTY	PART NUMBER	DESCRIPTION
1	2	LD25-0062-4	SAFETY GATE FRAME
2	2	LD25-0063-6	SAFETY GATE PANEL
3	1	LD25-0094-4	GUARD BRACE
4	6	FSHM025P10	SHCS M8x25
5	2	FSHM025P10	SOC. HD. CAP SCREW M6 X 25
6	2	SPH-1485	M6 DISTORTED THREAD HEX NUT
7	6	SPH-1486	M6 DISTORTED THREAD HEX NUT
8	32	FLWMFP	FLAT WASHER M5
9	32	FLWMFP	LOCK WASHER M5
10	32	FHFNMFP	HEX NUT M5
11	32	FBHMF016P10	BHCS M5 X 16

MATL	PART#	CAD FILE	SGA-LD24.idw	TOLERANCES UNLESS OTHERWISE NOTED:	LOVESHAW an ITW Company RT. 296, SOUTH CANAAN, PA.
BT ST.	STD	PLOT DATE	10/11/2011	X = ±.000 YCH .XX = ±.015 XXX = ±.005 ANGLE = ±.02°	
STAINLESS - NO FINISH		DO NOT SCALE PRINT		X = ±1.0mm METRIC .XX = ±.0mm .XXX = ±.1mm FRACTIONS 1/64	TITLE SAFETY GATE ASSEMBLY
THIS DRAWING AND SUBJECT MATTER THEREON IS THE EXCLUSIVE PROPERTY OF LOVESHAW AND SHALL BE TREATED BY YOU AS CONFIDENTIAL, PROPRIETARY INFORMATION. THE DRAWING OR SUBJECT MATTER THEREON SHALL NOT BE REPRODUCED OTHER THAN FOR YOUR OWN USE OR TO BE DISCLOSED TO OTHERS WITHOUT THE EXPRESS WRITTEN CONSENT OF LOVESHAW AND SHALL BE RETURNED TO LOVESHAW UPON REQUEST.				MACH FRESH DWG NO. SPA-LD24 SCALE	MATERIAL DRAWN BRYCEF CHECKED APPROVED

REVISION HISTORY			
REV	DESCRIPTION	DATE	BY
A	RELEASED	3/15/2012	BJF

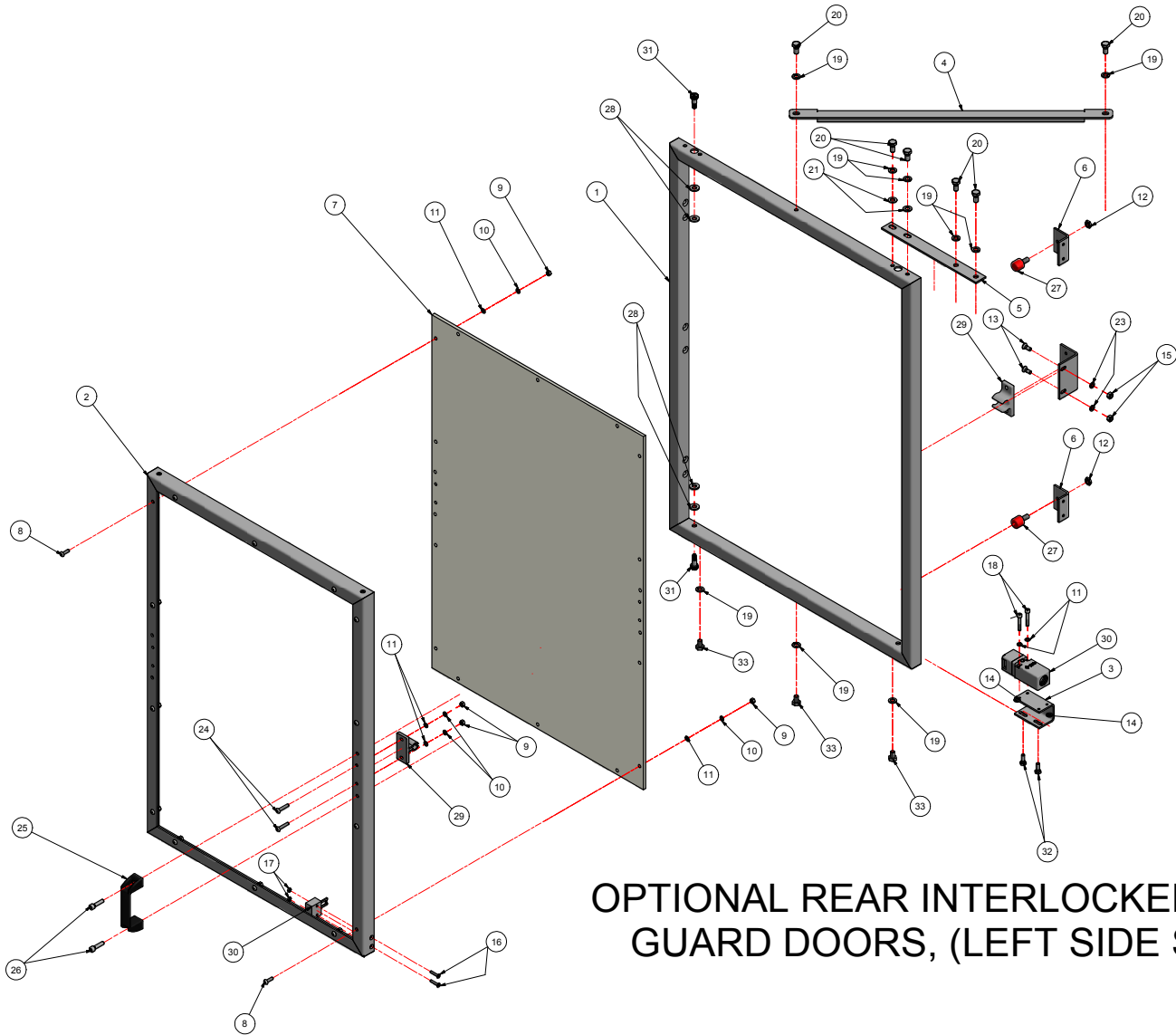

Parts List			
ITEM	QTY	PART NUMBER	DESCRIPTION
1	1	LD25-0134-6	SAFETY GATE FRAME, LD24
2	1	LD25-0135-6	SAFETY GATE DOOR FRAME, LD24
3	1	LD25-0136-4	SWITCH BRACKET
4	1	LD25-0137-6	SAFETY GATE BRACE
5	1	LD25-0138-4	BRACE SAFETY GATE, BAR
6	2	LD25-0139-4	BUMPER BRACKET
7	1	LD25-0140-6	SAFETY GATE PANEL
8	14	FBHMF016P10	BHCS M5 X 16
9	16	FHNMF	HEX NUT M5
10	16	FLWMFP	LOCK WASHER M5
11	20	FFWMFP	FLAT WASHER M5
12	2	FHNMHP	HEX JAM NUT, M8, PLATED
13	6	FFHMG016P10	FHCS M6 X 1.0 X 16 LG.
14	8	FLWMGP	LOCK WASHER M6
15	8	FHNMG	HEX NUT M6
16	2	FFHME020P10	M4x20 FLAT HEAD CAP SCREW
17	2	FHNMEP	M4 HEX NUT
18	2	FSHMF030P10	M5 x 30 SOCKET HEAD CAP SCREW
19	9	FLWMHP	LOCK WASHER M8
20	6	FHHMH016P10	HHCS M8 X 16
21	2	FFWMHP	FLAT WASHER M8
22	1	LD25-0141-4	LATCH MOUNT
23	4	FFWMGP	FLAT WASHER M6
24	2	FBHMF025P10	BUTTON HEAD CAP SCREW M5 x 25
25	1	HC-1004	U-HANDLE
26	2	FSHMG025P10	SOC. HD. CAP SCREW M6 X 25
27	2	SPH-1520	BUMPER, M8 MALE THREAD
28	4	SPH-1521	M8 NYLON WASHER
29	1	SPH-1522	DOOR LATCH
30	1	A195SG-TM4	SAFETY GATE SWITCH
31	2	F5BNMG12B10	M8 x 12 SHOULDER BOLT
32	2	FHHMG016P10	HHCS M6 X 16
33	3	FHHMH012P10	HEX HEAD M8 X 12
24	2	F5HMF016P10	M5-0.8 x 16 SHCS

OPTIONAL REAR INTERLOCKED SAFETY GUARD DOORS, (LEFT SIDE SHOWN)

MATL	PART#	CAD FILE	SGA-LD24 INT	TOLERANCES UNLESS OTHERWISE NOTED:	LOVESHAW an ITW Company RT. 296, SOUTH CANAAN, PA.
BT ST.	STD	PLOT DATE			
STAINLESS: NO FINISH		DO NOT SCALE PRINT		X=.0005 .001 .0015 .002 .0025 .003 .0035 .004 .0045 .005 .0055 .006 .0065 .007 .0075 .008 .0085 .009 .0095 .01 .0105 .011 .0115 .012 .0125 .013 .0135 .014 .0145 .015 .0155 .016 .0165 .017 .0175 .018 .0185 .019 .0195 .02 .0205 .021 .0215 .022 .0225 .023 .0235 .024 .0245 .025 .0255 .026 .0265 .027 .0275 .028 .0285 .029 .0295 .03 .0305 .031 .0315 .032 .0325 .033 .0335 .034 .0345 .035 .0355 .036 .0365 .037 .0375 .038 .0385 .039 .0395 .04 .0405 .041 .0415 .042 .0425 .043 .0435 .044 .0445 .045 .0455 .046 .0465 .047 .0475 .048 .0485 .049 .0495 .05 .0505 .051 .0515 .052 .0525 .053 .0535 .054 .0545 .055 .0555 .056 .0565 .057 .0575 .058 .0585 .059 .0595 .06 .0605 .061 .0615 .062 .0625 .063 .0635 .064 .0645 .065 .0655 .066 .0665 .067 .0675 .068 .0685 .069 .0695 .07 .0705 .071 .0715 .072 .0725 .073 .0735 .074 .0745 .075 .0755 .076 .0765 .077 .0775 .078 .0785 .079 .0795 .08 .0805 .081 .0815 .082 .0825 .083 .0835 .084 .0845 .085 .0855 .086 .0865 .087 .0875 .088 .0885 .089 .0895 .09 .0905 .091 .0915 .092 .0925 .093 .0935 .094 .0945 .095 .0955 .096 .0965 .097 .0975 .098 .0985 .099 .0995 .1 .1005 .101 .1015 .102 .1025 .103 .1035 .104 .1045 .105 .1055 .106 .1065 .107 .1075 .108 .1085 .109 .1095 .11 .1105 .111 .1115 .112 .1125 .113 .1135 .114 .1145 .115 .1155 .116 .1165 .117 .1175 .118 .1185 .119 .1195 .12 .1205 .121 .1215 .122 .1225 .123 .1235 .124 .1245 .125 .1255 .126 .1265 .127 .1275 .128 .1285 .129 .1295 .13 .1305 .131 .1315 .132 .1325 .133 .1335 .134 .1345 .135 .1355 .136 .1365 .137 .1375 .138 .1385 .139 .1395 .14 .1405 .141 .1415 .142 .1425 .143 .1435 .144 .1445 .145 .1455 .146 .1465 .147 .1475 .148 .1485 .149 .1495 .15 .1505 .151 .1515 .152 .1525 .153 .1535 .154 .1545 .155 .1555 .156 .1565 .157 .1575 .158 .1585 .159 .1595 .16 .1605 .161 .1615 .162 .1625 .163 .1635 .164 .1645 .165 .1655 .166 .1665 .167 .1675 .168 .1685 .169 .1695 .17 .1705 .171 .1715 .172 .1725 .173 .1735 .174 .1745 .175 .1755 .176 .1765 .177 .1775 .178 .1785 .179 .1795 .18 .1805 .181 .1815 .182 .1825 .183 .1835 .184 .1845 .185 .1855 .186 .1865 .187 .1875 .188 .1885 .189 .1895 .19 .1905 .191 .1915 .192 .1925 .193 .1935 .194 .1945 .195 .1955 .196 .1965 .197 .1975 .198 .1985 .199 .1995 .2 .2005 .201 .2015 .202 .2025 .203 .2035 .204 .2045 .205 .2055 .206 .2065 .207 .2075 .208 .2085 .209 .2095 .21 .2105 .211 .2115 .212 .2125 .213 .2135 .214 .2145 .215 .2155 .216 .2165 .217 .2175 .218 .2185 .219 .2195 .22 .2205 .221 .2215 .222 .2225 .223 .2235 .224 .2245 .225 .2255 .226 .2265 .227 .2275 .228 .2285 .229 .2295 .23 .2305 .231 .2315 .232 .2325 .233 .2335 .234 .2345 .235 .2355 .236 .2365 .237 .2375 .238 .2385 .239 .2395 .24 .2405 .241 .2415 .242 .2425 .243 .2435 .244 .2445 .245 .2455 .246 .2465 .247 .2475 .248 .2485 .249 .2495 .25 .2505 .251 .2515 .252 .2525 .253 .2535 .254 .2545 .255 .2555 .256 .2565 .257 .2575 .258 .2585 .259 .2595 .26 .2605 .261 .2615 .262 .2625 .263 .2635 .264 .2645 .265 .2655 .266 .2665 .267 .2675 .268 .2685 .269 .2695 .27 .2705 .271 .2715 .272 .2725 .273 .2735 .274 .2745 .275 .2755 .276 .2765 .277 .2775 .278 .2785 .279 .2795 .28 .2805 .281 .2815 .282 .2825 .283 .2835 .284 .2845 .285 .2855 .286 .2865 .287 .2875 .288 .2885 .289 .2895 .29 .2905 .291 .2915 .292 .2925 .293 .2935 .294 .2945 .295 .2955 .296 .2965 .297 .2975 .298 .2985 .299 .2995 .3 .3005 .301 .3015 .302 .3025 .303 .3035 .304 .3045 .305 .3055 .306 .3065 .307 .3075 .308 .3085 .309 .3095 .31 .3105 .311 .3115 .312 .3125 .313 .3135 .314 .3145 .315 .3155 .316 .3165 .317 .3175 .318 .3185 .319 .3195 .32 .3205 .321 .3215 .322 .3225 .323 .3235 .324 .3245 .325 .3255 .326 .3265 .327 .3275 .328 .3285 .329 .3295 .33 .3305 .331 .3315 .332 .3325 .333 .3335 .334 .3345 .335 .3355 .336 .3365 .337 .3375 .338 .3385 .339 .3395 .34 .3405 .341 .3415 .342 .3425 .343 .3435 .344 .3445 .345 .3455 .346 .3465 .347 .3475 .348 .3485 .349 .3495 .35 .3505 .351 .3515 .352 .3525 .353 .3535 .354 .3545 .355 .3555 .356 .3565 .357 .3575 .358 .3585 .359 .3595 .36 .3605 .361 .3615 .362 .3625 .363 .3635 .364 .3645 .365 .3655 .366 .3665 .367 .3675 .368 .3685 .369 .3695 .37 .3705 .371 .3715 .372 .3725 .373 .3735 .374 .3745 .375 .3755 .376 .3765 .377 .3775 .378 .3785 .379 .3795 .38 .3805 .381 .3815 .382 .3825 .383 .3835 .384 .3845 .385 .3855 .386 .3865 .387 .3875 .388 .3885 .389 .3895 .39 .3905 .391 .3915 .392 .3925 .393 .3935 .394 .3945 .395 .3955 .396 .3965 .397 .3975 .398 .3985 .399 .3995 .4 .4005 .401 .4015 .402 .4025 .403 .4035 .404 .4045 .405 .4055 .406 .4065 .407 .4075 .408 .4085 .409 .4095 .41 .4105 .411 .4115 .412 .4125 .413 .4135 .414 .4145 .415 .4155 .416 .4165 .417 .4175 .418 .4185 .419 .4195 .42 .4205 .421 .4215 .422 .4225 .423 .4235 .424 .4245 .425 .4255 .426 .4265 .427 .4275 .428 .4285 .429 .4295 .43 .4305 .431 .4315 .432 .4325 .433 .4335 .434 .4345 .435 .4355 .436 .4365 .437 .4375 .438 .4385 .439 .4395 .44 .4405 .441 .4415 .442 .4425 .443 .4435 .444 .4445 .445 .4455 .446 .4465 .447 .4475 .448 .4485 .449 .4495 .45 .4505 .451 .4515 .452 .4525 .453 .4535 .454 .4545 .455 .4555 .456 .4565 .457 .4575 .458 .4585 .459 .4595 .46 .4605 .461 .4615 .462 .4625 .463 .4635 .464 .4645 .465 .4655 .466 .4665 .467 .4675 .468 .4685 .469 .4695 .47 .4705 .471 .4715 .472 .4725 .473 .4735 .474 .4745 .475 .4755 .476 .4765 .477 .4775 .478 .4785 .479 .4795 .48 .4805 .481 .4815 .482 .4825 .483 .4835 .484 .4845 .485 .4855 .486 .4865 .487 .4875 .488 .4885 .489 .4895 .49 .4905 .491 .4915 .492 .4925 .493 .4935 .494 .4945 .495 .4955 .496 .4965 .497 .4975 .498 .4985 .499 .4995 .5 .5005 .501 .5015 .502 .5025 .503 .5035 .504 .5045 .505 .5055 .506 .5065 .507 .5075 .508 .5085 .509 .5095 .51 .5105 .511 .5115 .512 .5125 .513 .5135 .514 .5145 .515 .5155 .516 .5165 .517 .5175 .518 .5185 .519 .5195 .52 .5205 .521 .5215 .522 .5225 .523 .5235 .524 .5245 .525 .5255 .526 .5265 .527 .5275 .528 .5285 .529 .5295 .53 .5305 .531 .5315 .532 .5325 .533 .5335 .534 .5345 .535 .5355 .536 .5365 .537 .5375 .538 .5385 .539 .5395 .54 .5405 .541 .5415 .542 .5425 .543 .5435 .544 .5445 .545 .5455 .546 .5465 .547 .5475 .548 .5485 .549 .5495 .55 .5505 .551 .5515 .552 .5525 .553 .5535 .554 .5545 .555 .5555 .556 .5565 .557 .5575 .558 .5585 .559 .5595 .56 .5605 .561 .5615 .562 .5625 .563 .5635 .564 .5645 .565 .5655 .566 .5665 .567 .5675 .568 .5685 .569 .5695 .57 .5705 .571 .5715 .572 .5725 .573 .5735 .574 .5745 .575 .5755 .576 .5765 .577 .5775 .578 .5785 .579 .5795 .58 .5805 .581 .5815 .582 .5825 .583 .5835 .584 .5845 .585 .5855 .586 .5865 .587 .5875 .588 .5885 .589 .5895 .59 .5905 .591 .5915 .592 .5925 .593 .5935 .594 .5945 .595 .5955 .596 .5965 .597 .5975 .598 .5985 .599 .5995 .6 .6005 .601 .6015 .602 .6025 .603 .6035 .604 .6045 .605 .	

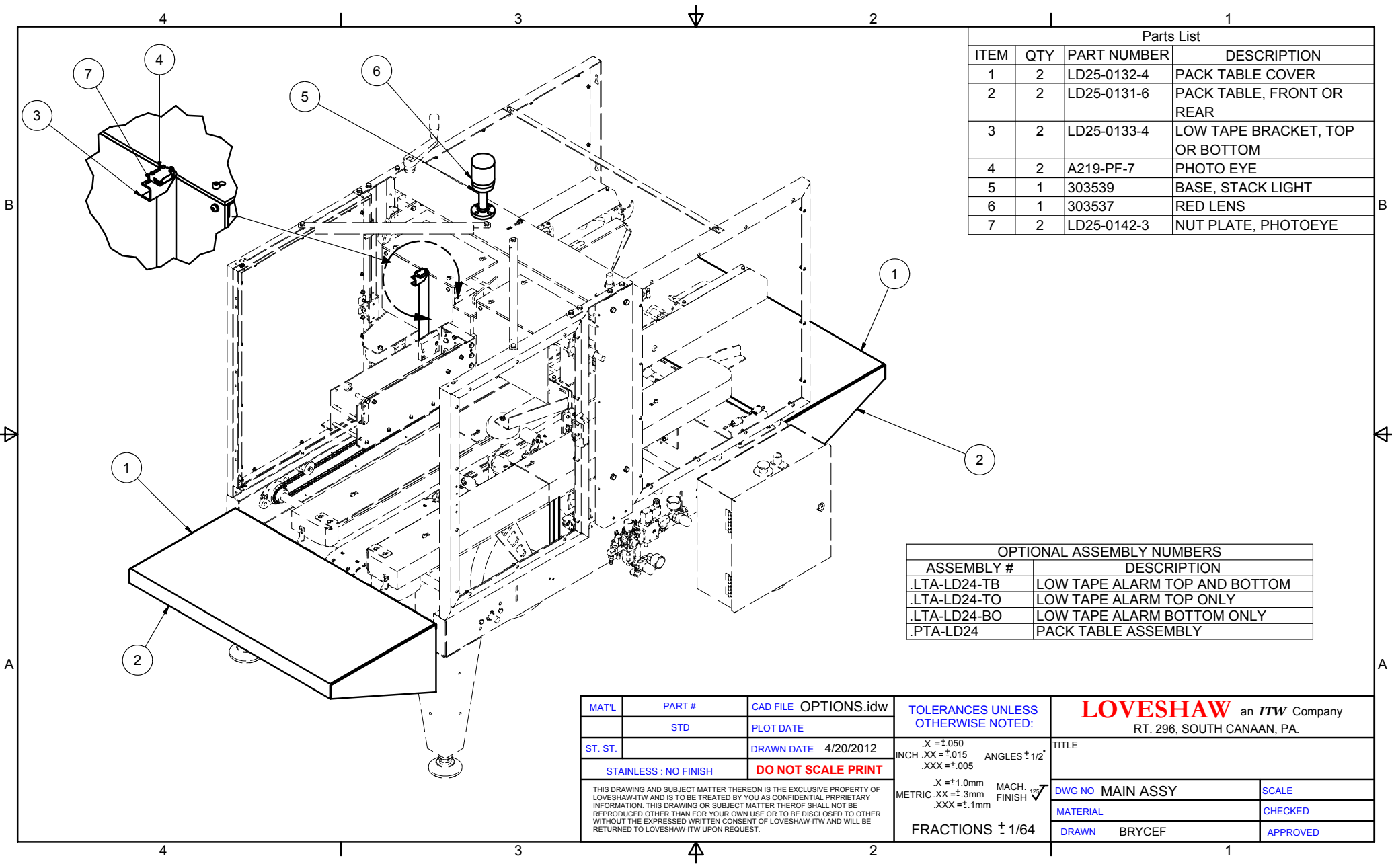

Parts List			
ITEM	QTY	PART NUMBER	DESCRIPTION
1	2	LD25-0132-4	PACK TABLE COVER
2	2	LD25-0131-6	PACK TABLE, FRONT OR REAR
3	2	LD25-0133-4	LOW TAPE BRACKET, TOP OR BOTTOM
4	2	A219-PF-7	PHOTO EYE
5	1	303539	BASE, STACK LIGHT
6	1	303537	RED LENS
7	2	LD25-0142-3	NUT PLATE, PHOTOEYE

OPTIONAL ASSEMBLY NUMBERS	
ASSEMBLY #	DESCRIPTION
.LTA-LD24-TB	LOW TAPE ALARM TOP AND BOTTOM
.LTA-LD24-TO	LOW TAPE ALARM TOP ONLY
.LTA-LD24-BO	LOW TAPE ALARM BOTTOM ONLY
.PTA-LD24	PACK TABLE ASSEMBLY

MATL	PART #	CAD FILE OPTIONS.idw	TOLERANCES UNLESS OTHERWISE NOTED: X = ±.050 INCH .XX = ±.015 ANGLES ± 1/2° .XXX = ±.005 X = ±1.0mm MACH. FINISH ✓ METRIC .XX = ±.3mm .XXX = ±.1mm FRACTIONS ± 1/64	LOVESHAW an ITW Company RT. 296, SOUTH CANAAN, PA. TITLE	
ST. ST.	STD	PLOT DATE			
STAINLESS : NO FINISH		DO NOT SCALE PRINT		DWG NO	MAIN ASSY
THIS DRAWING AND SUBJECT MATTER THEREON IS THE EXCLUSIVE PROPERTY OF LOVESHAW-ITW AND IS TO BE TREATED BY YOU AS CONFIDENTIAL PROPRIETARY INFORMATION. THIS DRAWING OR SUBJECT MATTER THEREOF SHALL NOT BE REPRODUCED OTHER THAN FOR YOUR OWN USE OR TO BE DISCLOSED TO OTHER WITHOUT THE EXPRESSED WRITTEN CONSENT OF LOVESHAW-ITW AND WILL BE RETURNED TO LOVESHAW-ITW UPON REQUEST.				MATERIAL	CHECKED
				DRAWN	BRYCEF

REVISION RECORD					
REV	DESCRIPTION	DATE	ATH	DR	CK
A	RELEASED	5/11/11		BJF	

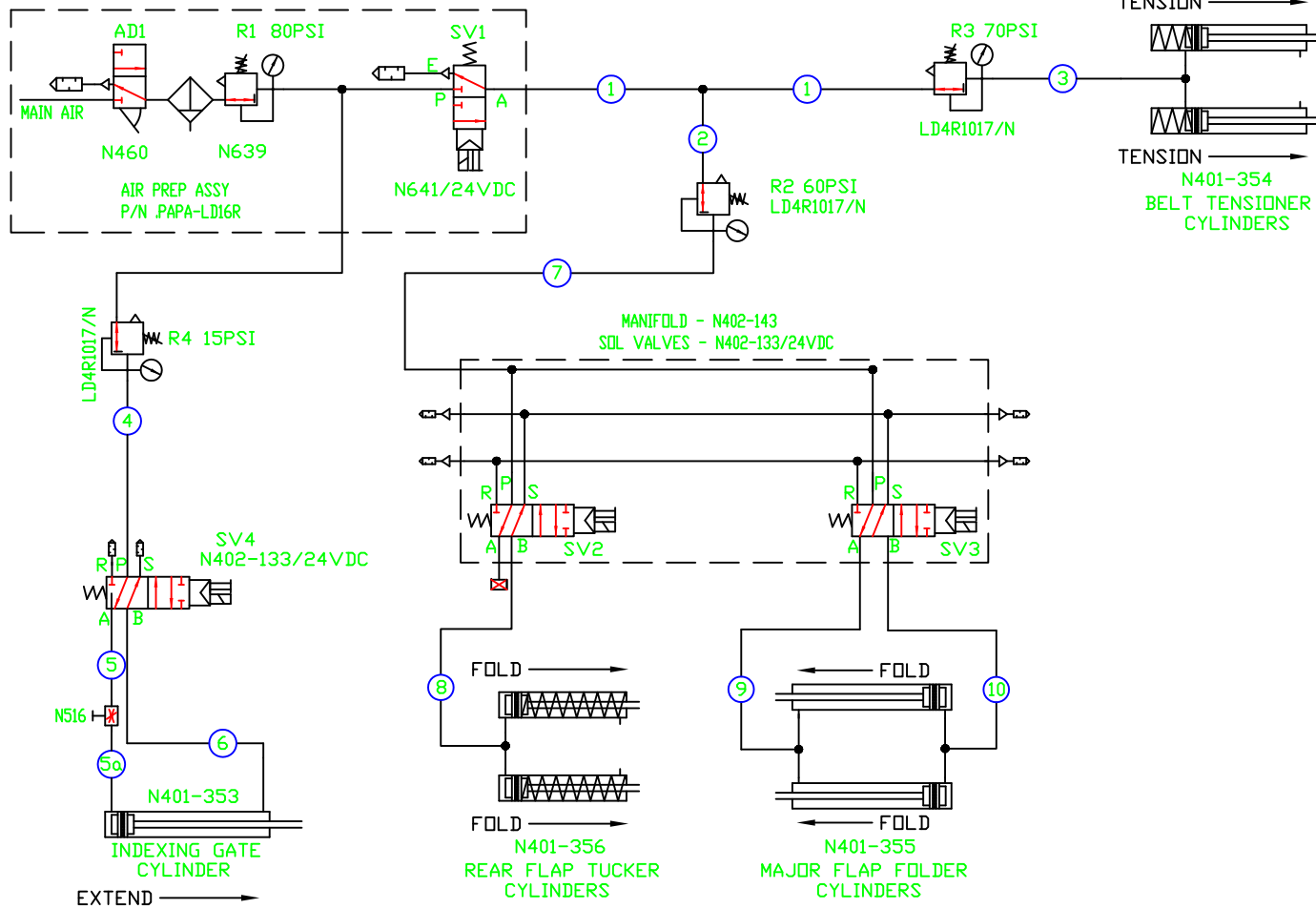

MAT'L	PART #	CAD FILE: G83970
	STD	PLOT DATE: 9/19/12
ST. ST.		DRAWN DATE: 5/11/11
STAINLESS: NO FINISH	DO NOT SCALE PRINT	
THIS DRAWING AND SUBJECT MATTER THEREON IS THE EXCLUSIVE PROPERTY OF LOVESHAW-ITW AND IS TO BE TREATED BY YOU AS CONFIDENTIAL PROPRIETARY INFORMATION. THIS DRAWING OR SUBJECT MATTER THEREOF SHALL NOT BE REPRODUCED OTHER THAN FOR YOUR OWN USE OR TO BE DISCLOSED TO OTHERS WITHOUT THE EXPRESS WRITTEN CONSENT OF LOVESHAW-ITW AND WILL BE RETURNED TO LOVESHAW-ITW UPON REQUEST.		

TOLERANCES UNLESS OTHERWISE NOTED:	
INCH	.X = ±.050 .XX = ±.015 .XXX = ±.005
METRIC	.X = ±1.0mm .XX = ±.3mm .XXX = ±.1mm
ANGLES	±1/2° FRACTIONS ±1/64
MACHINE FINISH	√

LOVESHAW an ITW Company RT. 296, SOUTH CANAAN, PA.	
TITLE: PNEUMATIC SCHEMATIC LD24	
DWG. #: PNEU-0236-4	SCALE: N/A
MATERIAL:	CHECK'D:
DESIGNED:	DRAWN: BJF
	APPR'D:

REVISION RECORD					
REV	DESCRIPTION	DATE	ATH	DR	CK

KEY	PART NO.	DESCRIPTION
1	A100N-161606.62	ENCLOSURE
2	A100N-PP-HDF-1	PRINT POCKEY
3	LD12B-2074-ABF	RED MUSHROOMM HEAD PB ASSY.
4	A213-AB-RD-F	E-STOP LEGEND PLATE
5	LD12B-2073-ABF	GREEN FLUSH HEAD PB ASSY.
6	A214-AB-1-F	START LEGEND PLATE

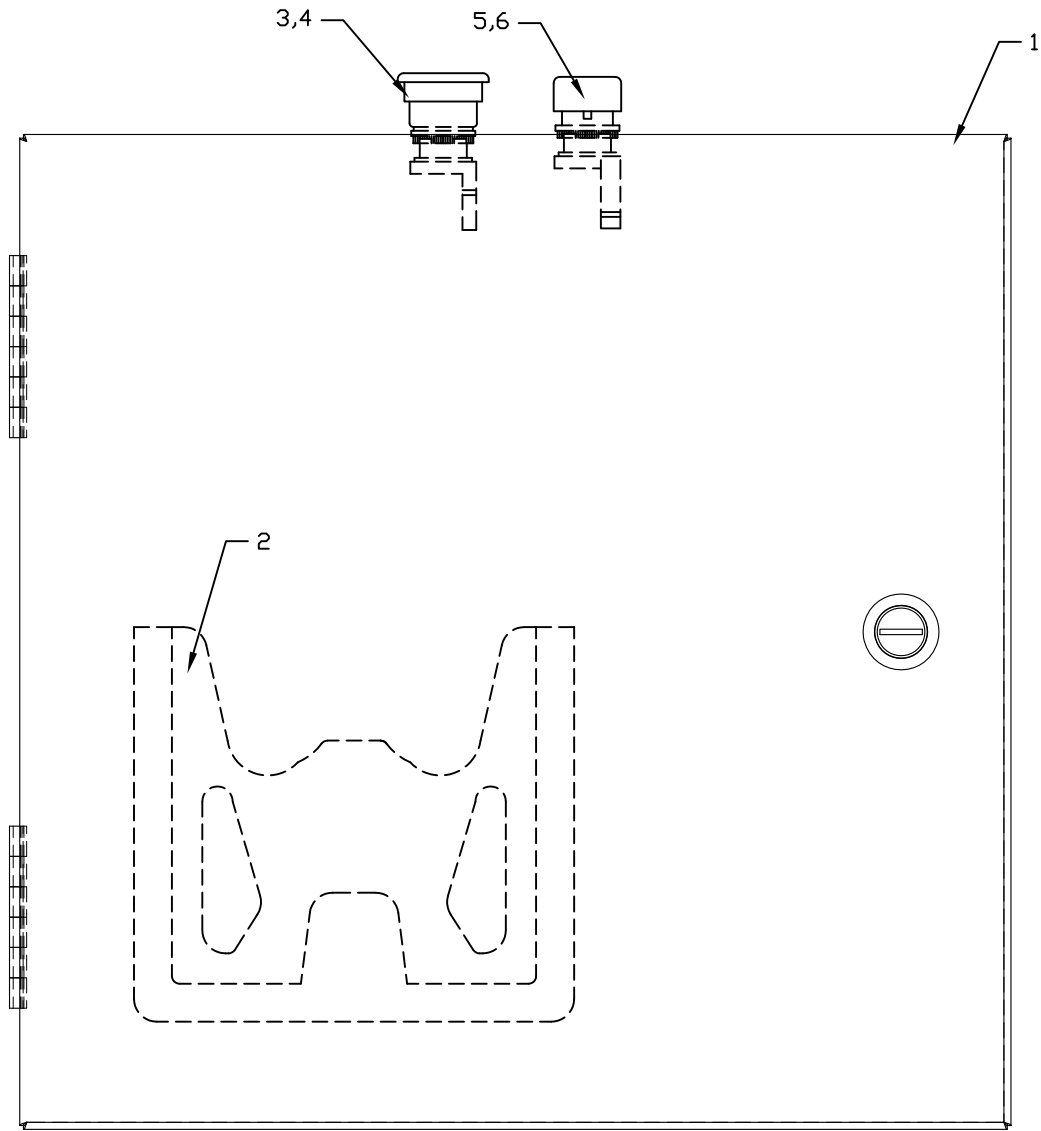

TOLERANCES EXCEPT AS NOTED	THE LOVESHAW CORPORATION RT 296, SOUTH CANAAN, PA.	
DECIMAL (3 PLC) +/- .005	TITLE: ENCLOSURE ASSEMBLY LD24 - 120/1/60	
FRACTIONAL +/- 1/64	DWG. NO. ED2314	SCALE: 1 : 2
ANG. - 1/2°	MATERIAL: COMMERCIAL	DATE: 06/21/11
	DESIGNED: MENTA	DRAWN: WM
		APPRVD: --

REVISION RECORD					
REV	DESCRIPTION	DATE	ATH	DR	CK

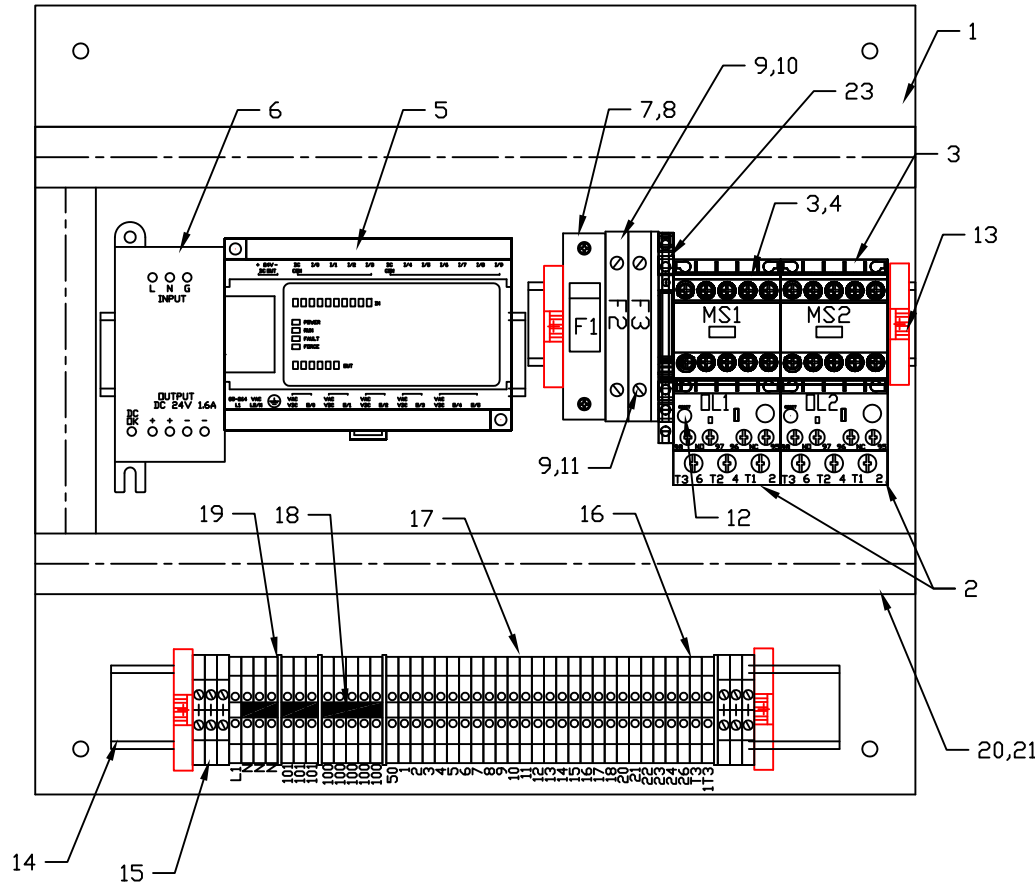

KEY	PART NO.	DESCRIPTION
1	A100N-16X16P	PANEL
2	LP05-AB-K-4.8	OVERLOAD RELAY
3	A106-AB-K-24	CONTACTOR
4	A106-AB-K-AUX	AUX CONTACT BLOCK
5	A241AB-1000-6	PLC
6	A241AB-830-PS	POWER SUPPLY
7	A125BH-AB-DIN-3	FUSE HOLDER
8	A125SB-12-R	FUSE, 12 AMP
9	A125BH-AB-DIN	FUSE HOLDER DIN RAIL
10	A125SB-1-326	FUSE, 1 AMP
11	A125SB-1.5-326	FUSE, 1.5 AMP
12	A128B-AB16	BARRIER FUSE BLOCK
13	A128-AB-ERL35	TERMINAL ANCHOR
14	A209-AB-2	DIN RAIL
15	A124-AB-JG4	GROUND TERMINAL
16	A128-AB-EBJ3	BARRIER PLATE
17	A124-AB-J3	SINGLE TERMINAL BLOCK
18	A124-AB-CJ-10	10 POLE JUMPER
19	A128-AB-PPJ3	SEPARATION PLATE
20	A250-PAN-1X1.5	WIREWAY
21	A250-PAN-1X1.5C	WIREWAY COVER
22	A124-AB-MARK-ST	MARKER CARD
23	A183-AB-11	RELAY

TOLERANCES EXCEPT AS NOTED	THE LOVESHAW CORPORATION RT 296, SOUTH CANAAN, PA.	
DECIMAL (3 PLC) +/- .005	TITLE: PANEL ASSEMBLY LD24 - 120/1/60	
FRACTIONAL +/- 1/64	DWG. NO. ED2308	SCALE: 1 : 2
ANG. - 1/2"	MATERIAL: COMMERCIAL	DATE: 06/21/11
	DESIGNED: MENTA	DRAWN: WM
		APPRVD: --

101 ← CONTINUED FROM SHEET 2, LINE 220 → 100

CONTINUED FROM SHEET 3

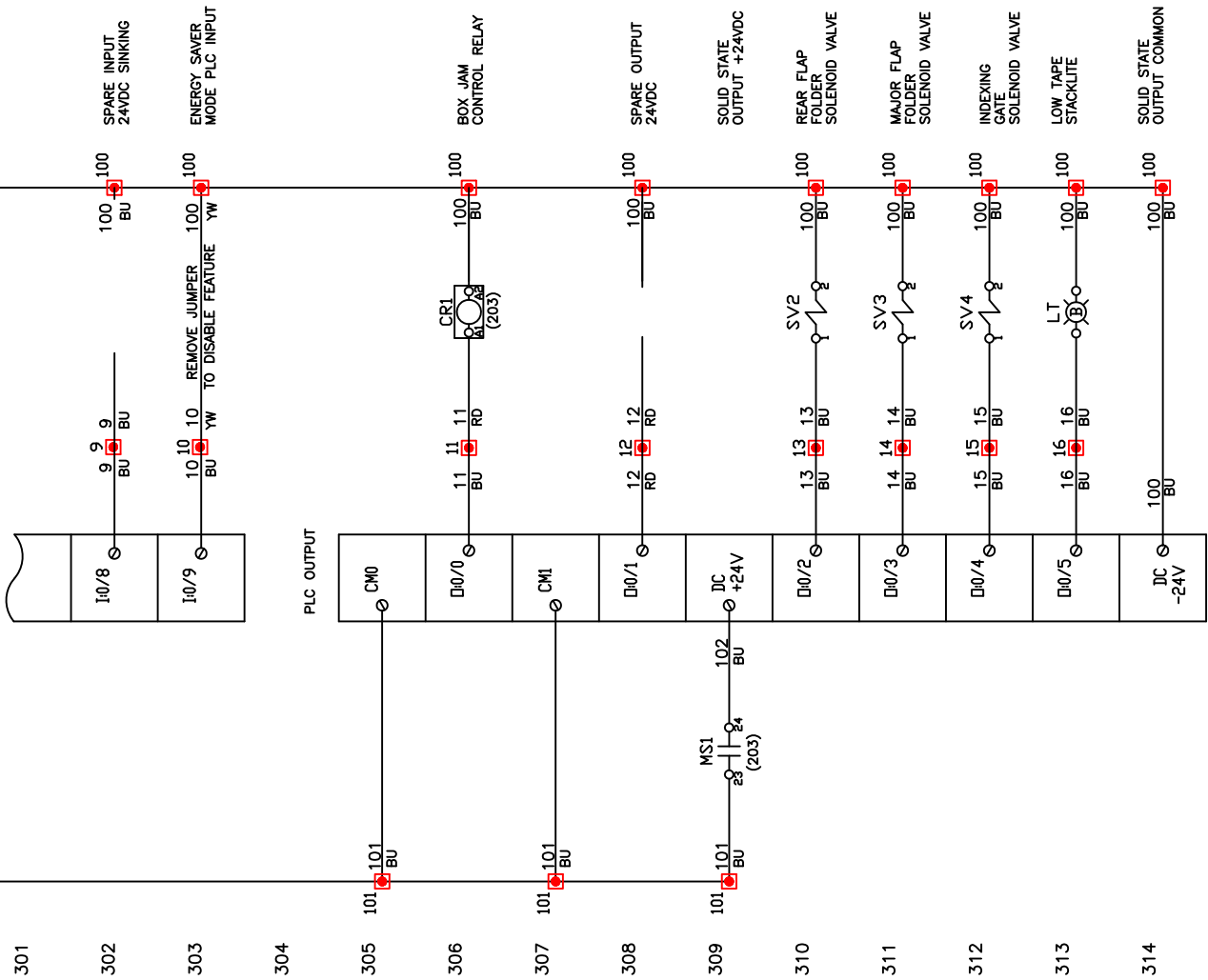

WIRE CONNECTION KEY

100	TERMINAL BLOCK LOCATED ON TERMINAL STRIP.
100	WIRE CONNECTION ON ELECTRICAL COMPONENT.

- WIRING NOTES:**
1. WIRE COLORS ARE AS NOTED.
 2. AC CONTROL WIRE RED 18AWG.
 3. DC CONTROL WIRE 18AWG BLUE.

TOLERANCES EXCEPT AS NOTED	THE LOVESHAW CORPORATION RT 296, SOUTH CANAAN, PA.	
DECIMAL (3 PLC) +/- .005	TITLE: ELECTRICAL SCHEMATIC - SHEET 3 LD24T - 120/1/60	
FRACTIONAL +/- 1/64	DWG. NO. ED2313S3	SCALE: N/A
ANG. - 1/2°	MATERIAL: N/A	DATE: 06/20/11
	DESIGNED: MENTA	DRAWN: WM
		APPRVD: --

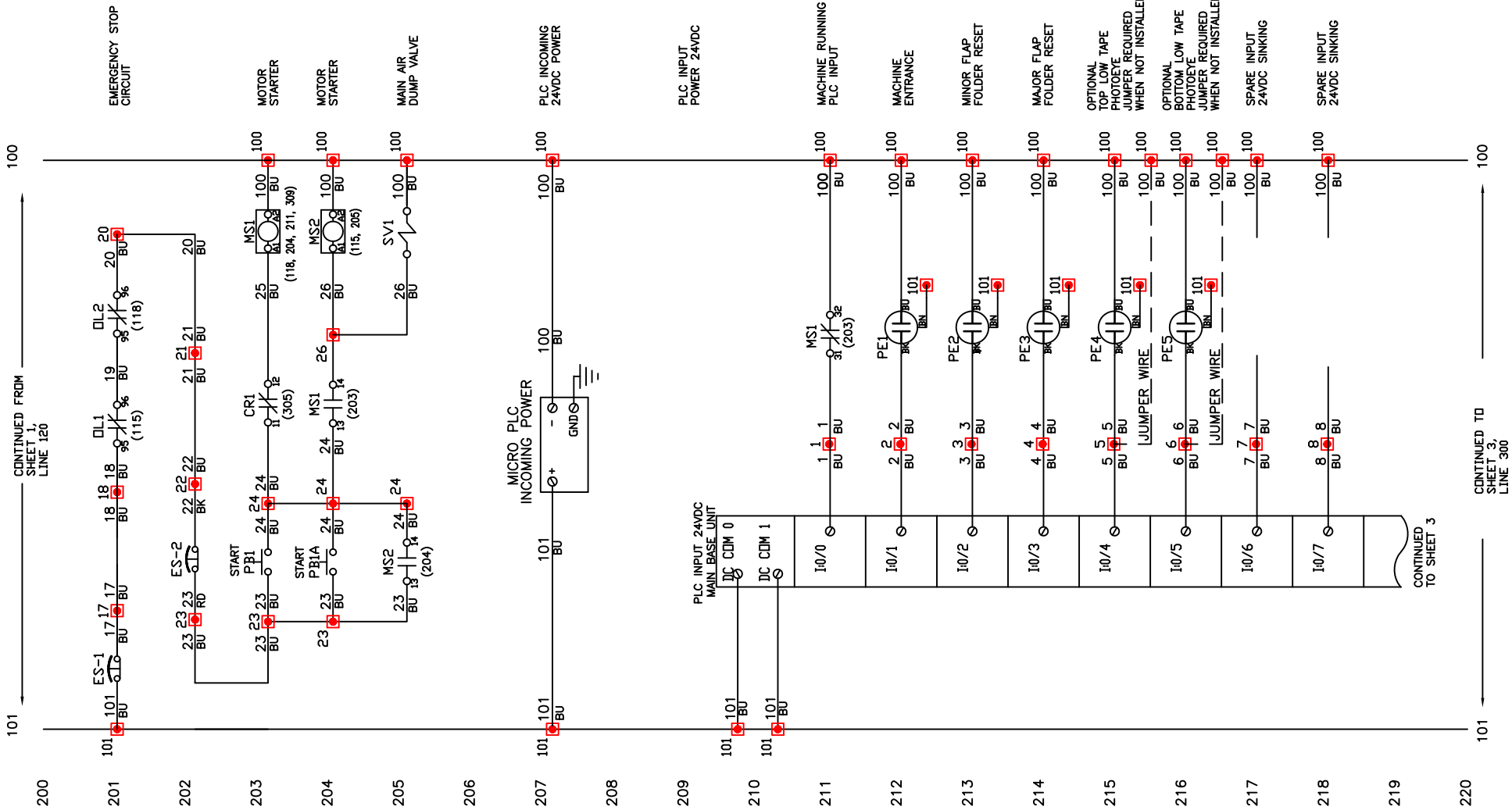

101 ← CONTINUED FROM SHEET 1, LINE 120 → 100

101 → CONTINUED TO SHEET 3, LINE 300 ←

WIRE CONNECTION KEY

100	TERMINAL BLOCK LOCATED ON TERMINAL STRIP.
100	WIRE CONNECTION ON ELECTRICAL COMPONENT.

- WIRING NOTES:**
1. WIRE COLORS ARE AS NOTED.
 2. AC CONTROL WIRE RED 18AWG.
 3. DC CONTROL WIRE BLUE 18AWG.

TOLERANCES EXCEPT AS NOTED	THE LOVESHAW CORPORATION RT 296, SOUTH CANAAN, PA.	
DECIMAL (3 PLC) +/- .005	TITLE: ELECTRICAL SCHEMATIC - SHEET 2 LD24T - 120/1/60	
FRACTIONAL +/- 1/64	DWG. NO. ED2313S2	SCALE: N/A
ANG. - 1/2"	MATERIAL: N/A	DATE: 06/20/11
	DESIGNED: MENTA	DRAWN: WM
		APPRVD: --

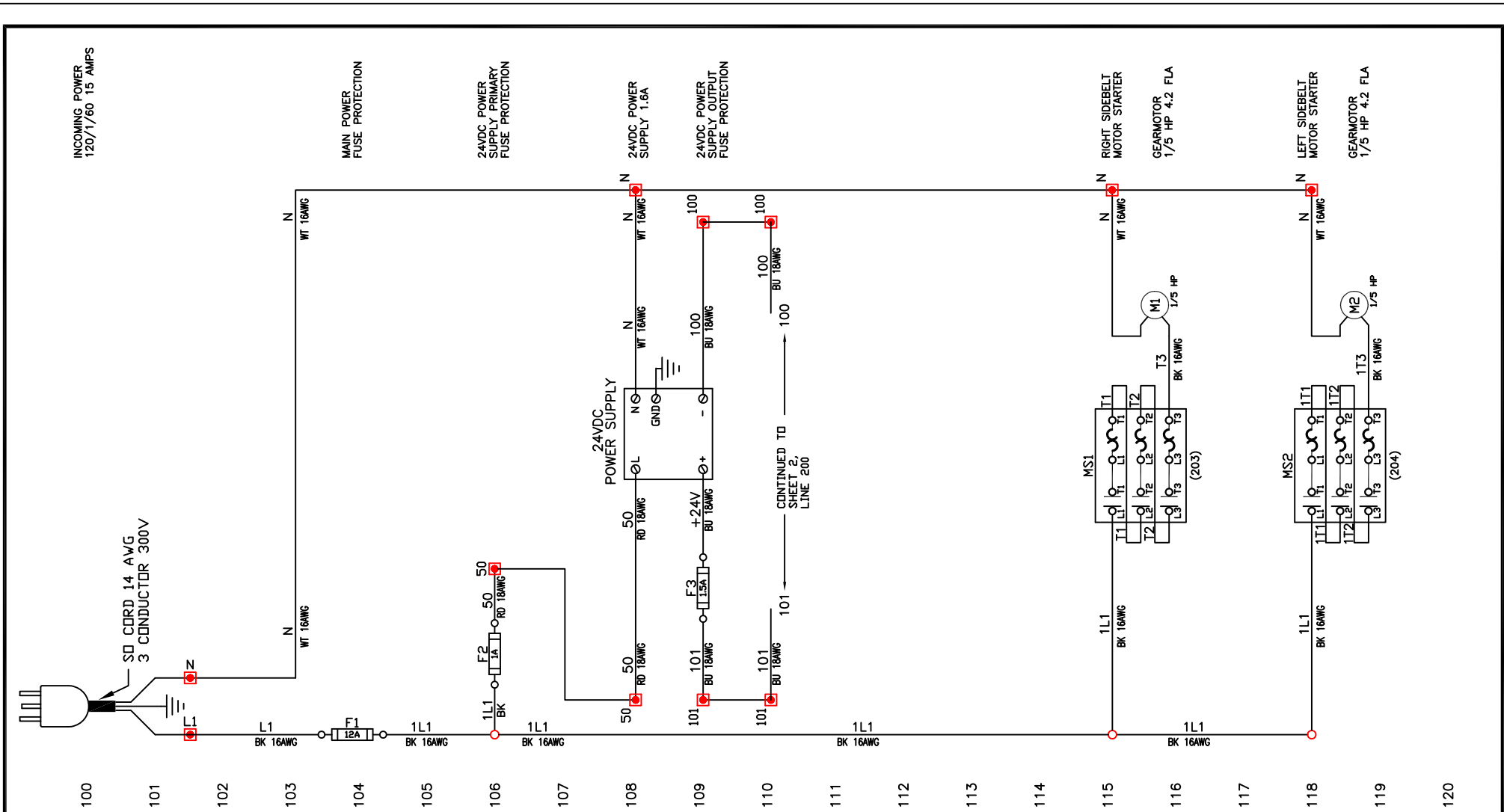

INCOMING POWER
120/1/60 15 AMPS

MAIN POWER
FUSE PROTECTION

24VDC POWER
SUPPLY PRIMARY
FUSE PROTECTION

24VDC POWER
SUPPLY 1.5A

24VDC POWER
SUPPLY OUTPUT
FUSE PROTECTION

RIGHT SIDEBELT
MOTOR STARTER

GEARMOTOR
1/5 HP 4.2 FLA

LEFT SIDEBELT
MOTOR STARTER

GEARMOTOR
1/5 HP 4.2 FLA

WIRE CONNECTION KEY

100	TERMINAL BLOCK LOCATED ON TERMINAL STRIP.
100	WIRE CONNECTION ON ELECTRICAL COMPONENT.

- WIRING NOTES:**
1. WIRE COLORS ARE AS NOTED.
 2. AC CONTROL WIRE RED 18AWG.
 3. MOTOR CABLE IS 18AWG 3 COND.

TOLERANCES EXCEPT AS NOTED	THE LOVESHAW CORPORATION RT 296, SOUTH CANAAN, PA.	
DECIMAL (3 PLC) +/- .005	TITLE: ELECTRICAL SCHEMATIC - SHEET 1 LD24T - 120/1/60	
FRACTIONAL +/- 1/64	DWG. NO. ED2313S1	SCALE: N/A
ANG. - 1/2"	MATERIAL: N/A	DATE: 06/20/11
	DESIGNED: MENTA	DRAWN: WM
		APPRVD: --

LOVESHAW - LD24T - CASE SEALER LADDER LOGIC - LD24_11R1.RSS

**ROCKWELL
SOFTWARE**



RSLogix 500

Programming For The
SLC500 and
MicroLogix Families

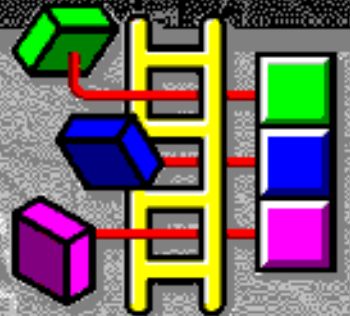

This program is protected by U.S. and international copyright laws as described in the About Box.



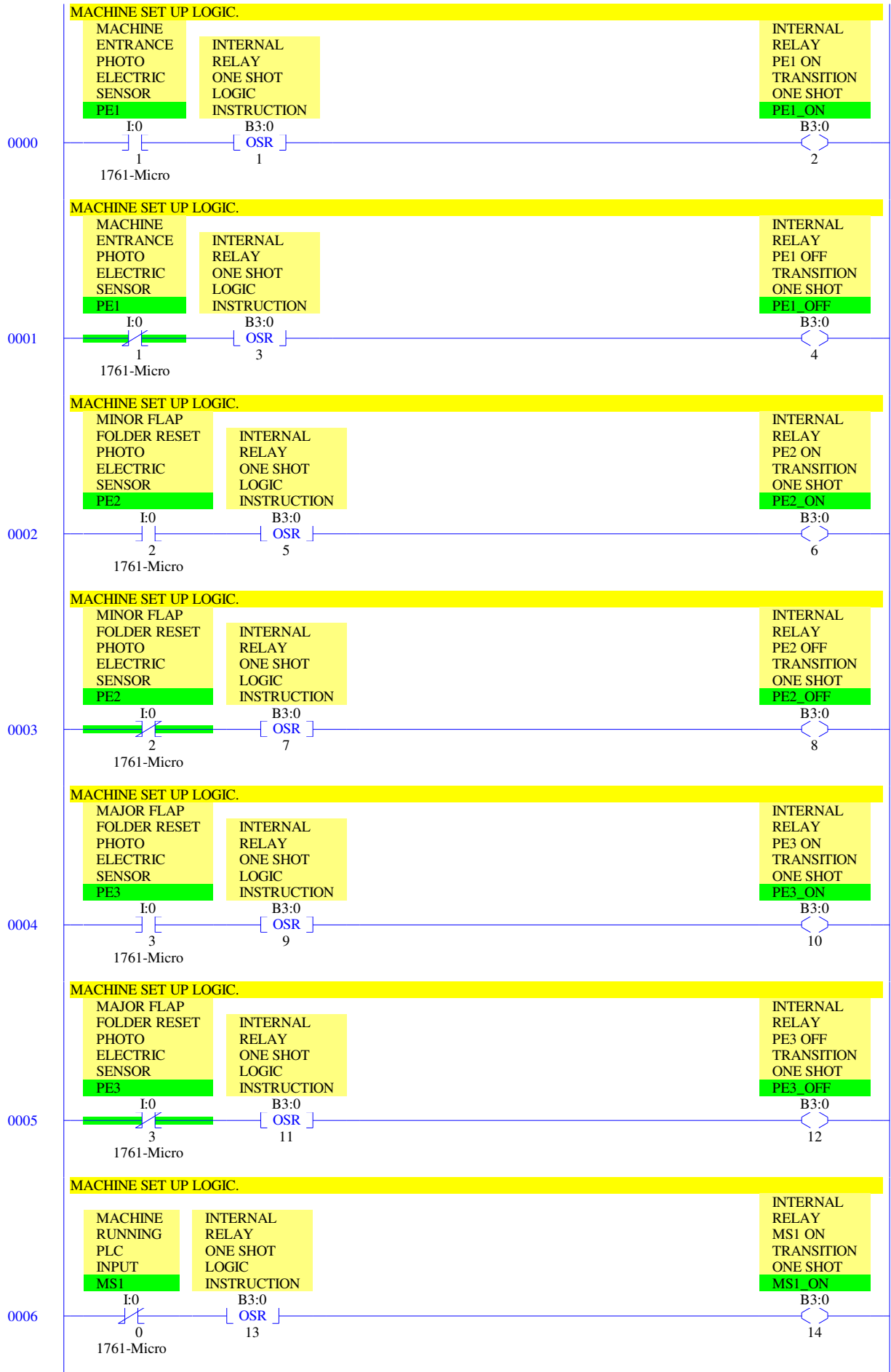

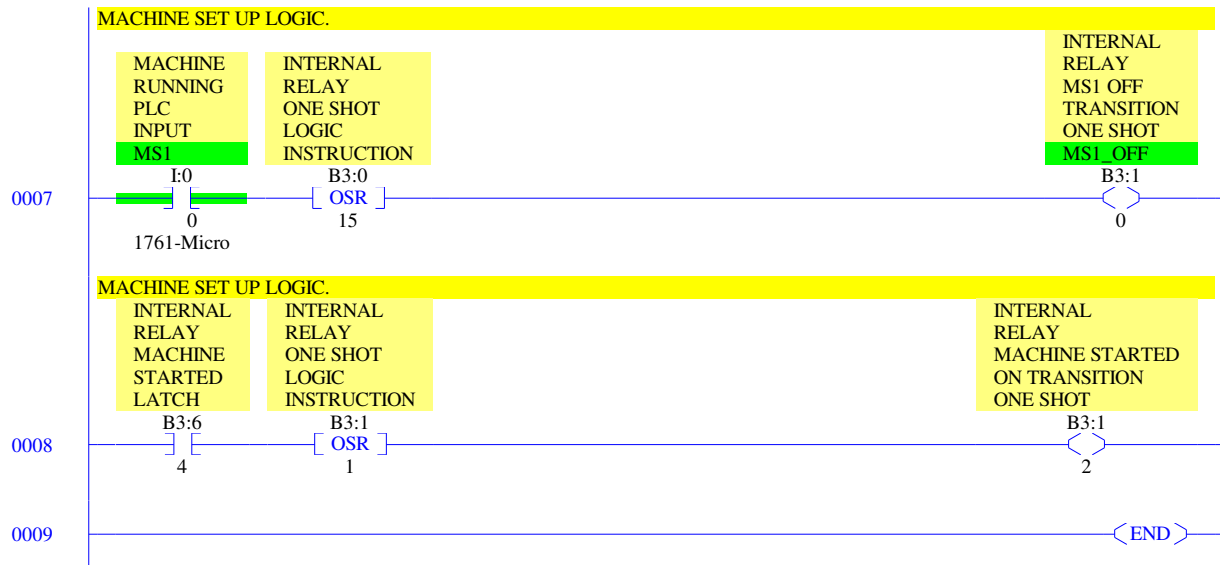

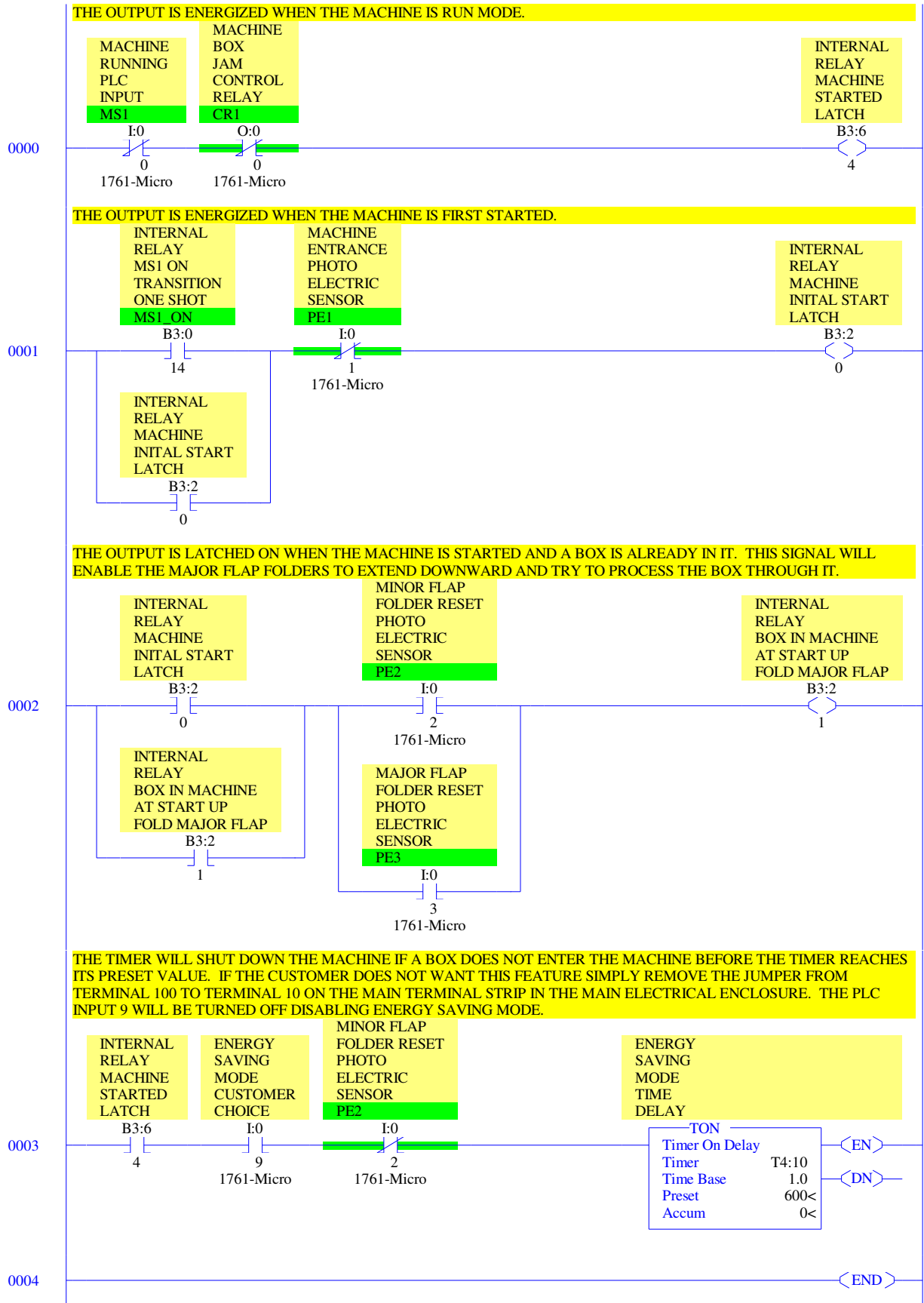

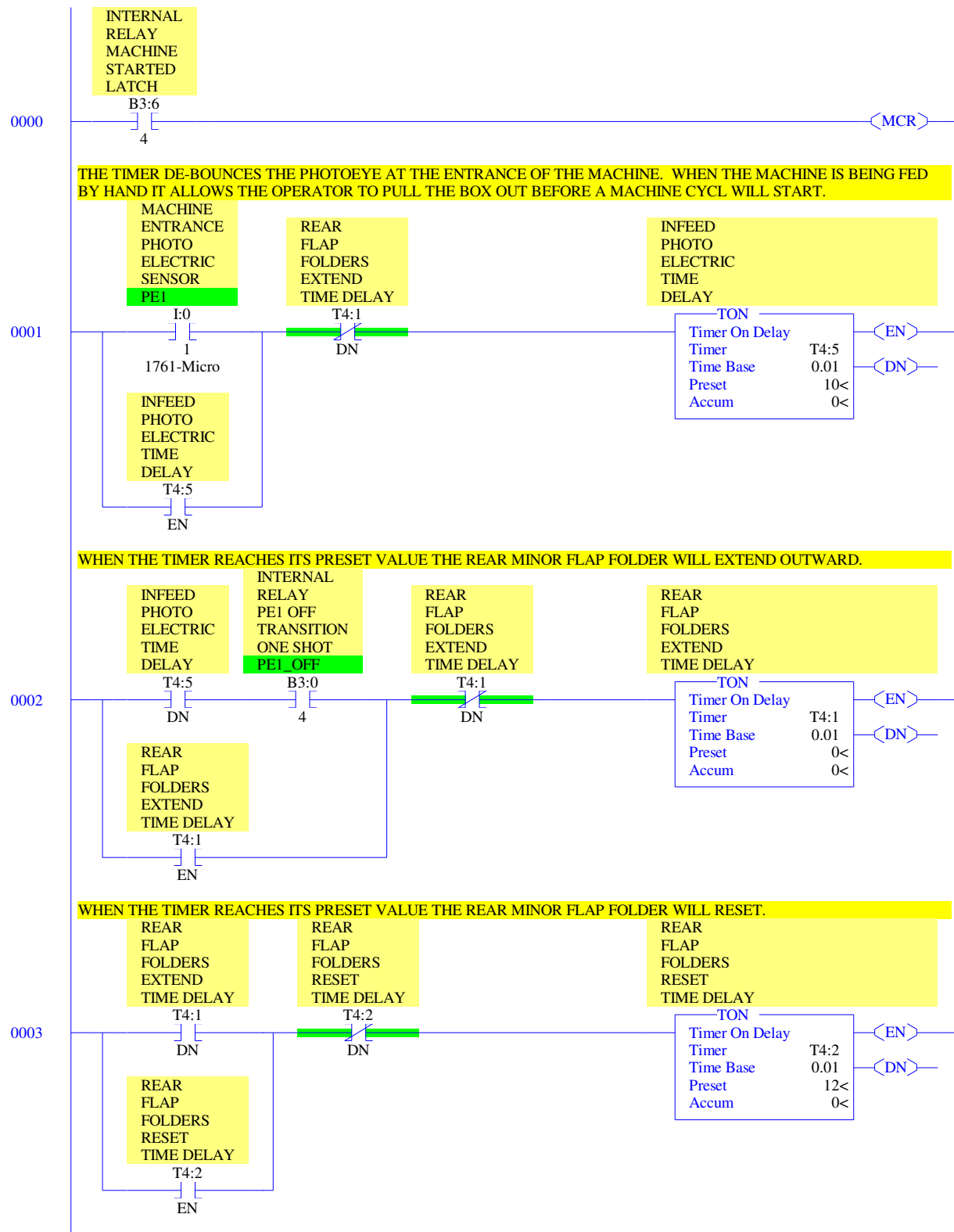

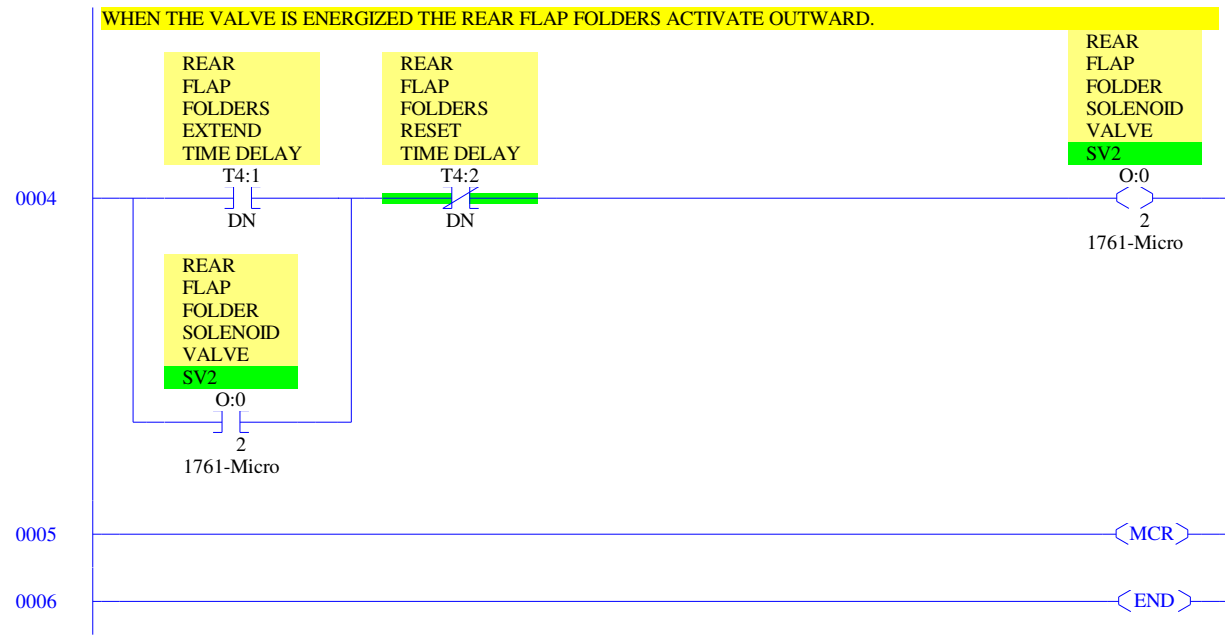

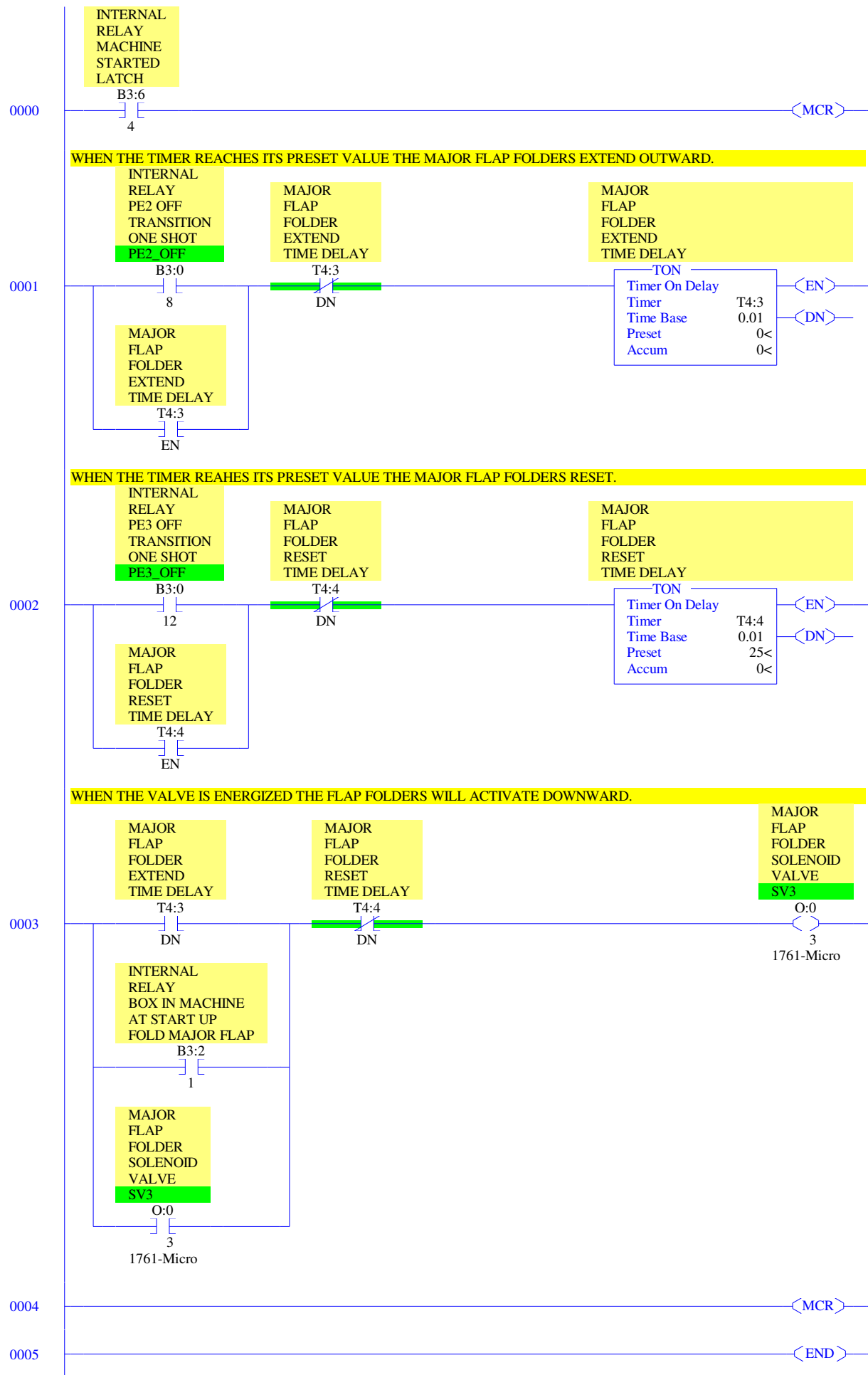

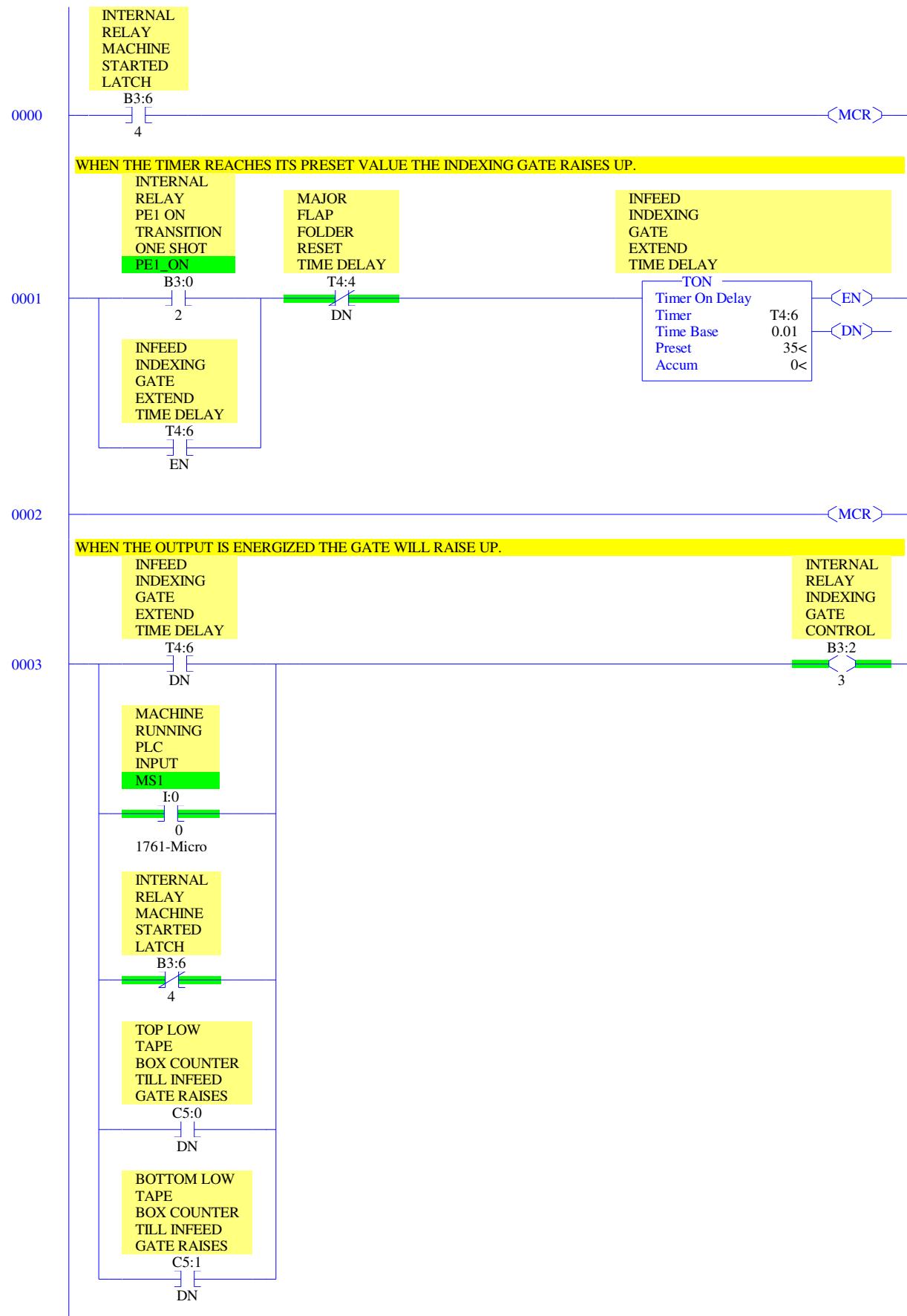

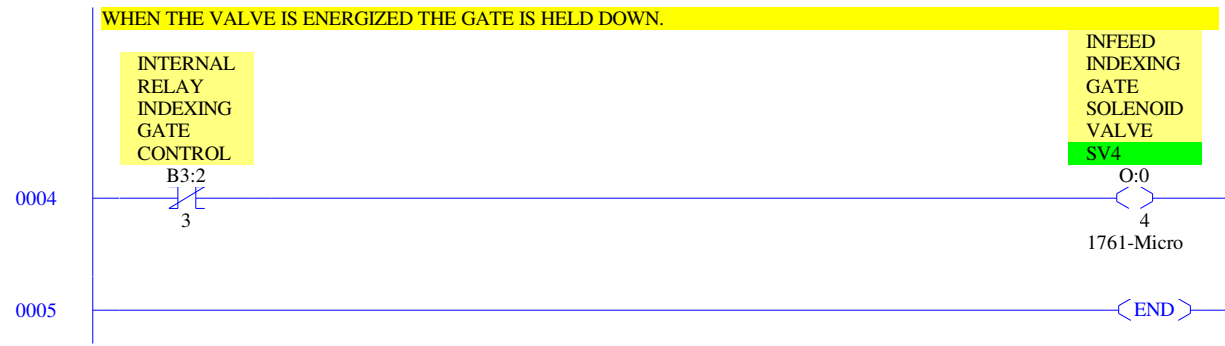

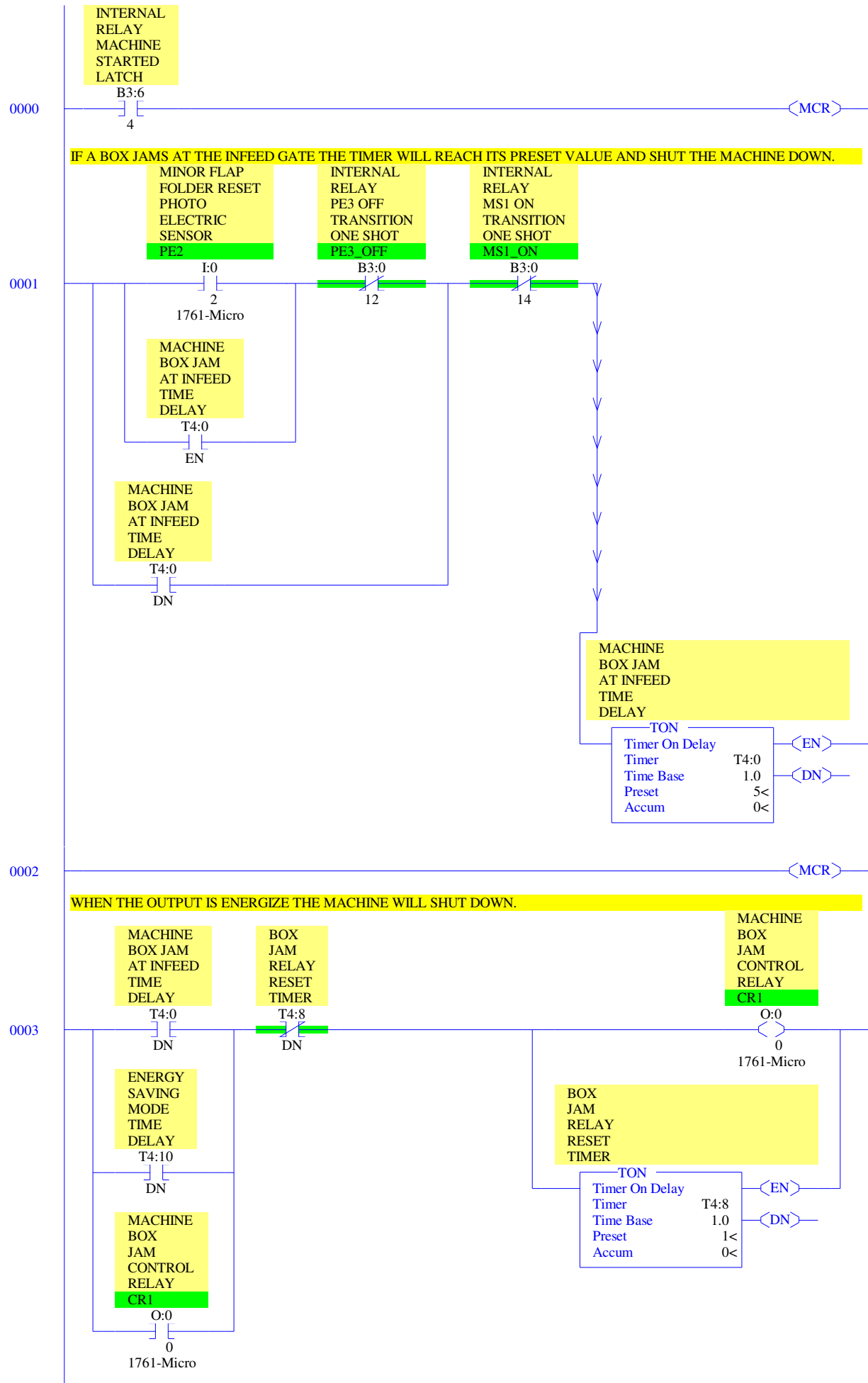

0004

END

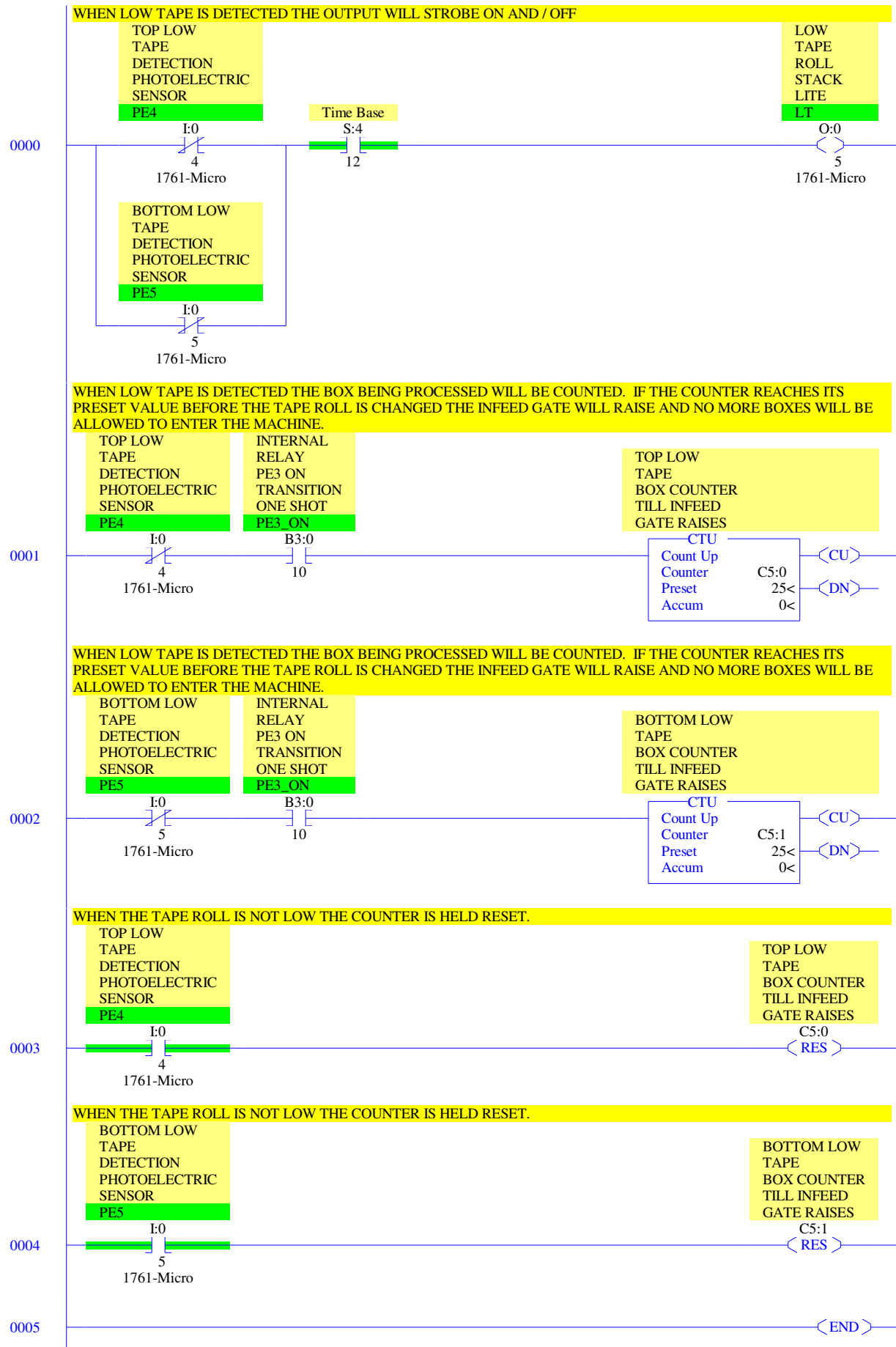

```

O:0/0      - {CR1} MACHINE BOX JAM CONTROL RELAY
           OTE - File #8 BOX JAM - 3
           XIC - File #8 BOX JAM - 3
           XIO - File #4 MACH START - 0
O:0/2      - {SV2} REAR FLAP FOLDER SOLENOID VALVE
           OTE - File #5 REAR FLAP - 4
           XIC - File #5 REAR FLAP - 4
O:0/3      - {SV3} MAJOR FLAP FOLDER SOLENOID VALVE
           OTE - File #6 MAJOR FLAP - 3
           XIC - File #6 MAJOR FLAP - 3
O:0/4      - {SV4} INFEED INDEXING GATE SOLENOID VALVE
           OTE - File #7 INDEXING - 4
O:0/5      - {LT} LOW TAPE ROLL STACK LITE
           OTE - File #9 LOW TAPE - 0
I:0/0      - {MS1} MACHINE RUNNING PLC INPUT
           XIC - File #3 CONDITION - 7
           File #7 INDEXING - 3
           XIO - File #3 CONDITION - 6
           File #4 MACH START - 0
I:0/1      - {PE1} MACHINE ENTRANCE PHOTO ELECTRIC SENSOR
           XIC - File #3 CONDITION - 0
           File #5 REAR FLAP - 1
           XIO - File #3 CONDITION - 1
           File #4 MACH START - 1
I:0/2      - {PE2} MINOR FLAP FOLDER RESET PHOTO ELECTRIC SENSOR
           XIC - File #3 CONDITION - 2
           File #4 MACH START - 2
           File #8 BOX JAM - 1
           XIO - File #3 CONDITION - 3
           File #4 MACH START - 3
I:0/3      - {PE3} MAJOR FLAP FOLDER RESET PHOTO ELECTRIC SENSOR
           XIC - File #3 CONDITION - 4
           File #4 MACH START - 2
           XIO - File #3 CONDITION - 5
I:0/4      - {PE4} TOP LOW TAPE DETECTION PHOTOELECTRIC SENSOR
           XIC - File #9 LOW TAPE - 3
           XIO - File #9 LOW TAPE - 0, 1
I:0/5      - {PE5} BOTTOM LOW TAPE DETECTION PHOTOELECTRIC SENSOR
           XIC - File #9 LOW TAPE - 4
           XIO - File #9 LOW TAPE - 0, 2
I:0/9      - ENERGY SAVING MODE CUSTOMER CHOICE
           XIC - File #4 MACH START - 3
S:4/12     - XIC - File #9 LOW TAPE - 0
B3:0/1     - INTERNAL RELAY ONE SHOT LOGIC INSTRUCTION
           OSR - File #3 CONDITION - 0
B3:0/2     - {PE1_ON} INTERNAL RELAY PE1 ON TRANSITION ONE SHOT
           OTE - File #3 CONDITION - 0
           XIC - File #7 INDEXING - 1
B3:0/3     - INTERNAL RELAY ONE SHOT LOGIC INSTRUCTION
           OSR - File #3 CONDITION - 1
B3:0/4     - {PE1_OFF} INTERNAL RELAY PE1 OFF TRANSITION ONE SHOT
           OTE - File #3 CONDITION - 1
           XIC - File #5 REAR FLAP - 2
B3:0/5     - INTERNAL RELAY ONE SHOT LOGIC INSTRUCTION
           OSR - File #3 CONDITION - 2
B3:0/6     - {PE2_ON} INTERNAL RELAY PE2 ON TRANSITION ONE SHOT
           OTE - File #3 CONDITION - 2
B3:0/7     - INTERNAL RELAY ONE SHOT LOGIC INSTRUCTION
           OSR - File #3 CONDITION - 3
B3:0/8     - {PE2_OFF} INTERNAL RELAY PE2 OFF TRANSITION ONE SHOT
           OTE - File #3 CONDITION - 3
           XIC - File #6 MAJOR FLAP - 1
B3:0/9     - INTERNAL RELAY ONE SHOT LOGIC INSTRUCTION
           OSR - File #3 CONDITION - 4
B3:0/10    - {PE3_ON} INTERNAL RELAY PE3 ON TRANSITION ONE SHOT
           OTE - File #3 CONDITION - 4
           XIC - File #9 LOW TAPE - 1, 2
B3:0/11    - INTERNAL RELAY ONE SHOT LOGIC INSTRUCTION
           OSR - File #3 CONDITION - 5
B3:0/12    - {PE3_OFF} INTERNAL RELAY PE3 OFF TRANSITION ONE SHOT
           OTE - File #3 CONDITION - 5
           XIC - File #6 MAJOR FLAP - 2
           XIO - File #8 BOX JAM - 1
B3:0/13    - INTERNAL RELAY ONE SHOT LOGIC INSTRUCTION
           OSR - File #3 CONDITION - 6
B3:0/14    - {MS1_ON} INTERNAL RELAY MS1 ON TRANSITION ONE SHOT
           OTE - File #3 CONDITION - 6
           XIC - File #4 MACH START - 1
           XIO - File #8 BOX JAM - 1
B3:0/15    - INTERNAL RELAY ONE SHOT LOGIC INSTRUCTION
           OSR - File #3 CONDITION - 7
B3:1/0     - {MS1_OFF} INTERNAL RELAY MS1 OFF TRANSITION ONE SHOT
           OTE - File #3 CONDITION - 7
B3:1/1     - INTERNAL RELAY ONE SHOT LOGIC INSTRUCTION
           OSR - File #3 CONDITION - 8
B3:1/2     - INTERNAL RELAY MACHINE STARTED ON TRANSITION ONE SHOT

```

```

B3:2/0      - OTE - File #3 CONDITION - 8
              - INTERNAL RELAY MACHINE INITIAL START LATCH
              OTE - File #4 MACH START - 1
              XIC - File #4 MACH START - 1, 2
B3:2/1      - INTERNAL RELAY BOX IN MACHINE AT START UP FOLD MAJOR FLAP
              OTE - File #4 MACH START - 2
              XIC - File #4 MACH START - 2
              File #6 MAJOR FLAP - 3
B3:2/3      - INTERNAL RELAY INDEXING GATE CONTROL
              OTE - File #7 INDEXING - 3
              XIO - File #7 INDEXING - 4
B3:6/4      - INTERNAL RELAY MACHINE STARTED LATCH
              OTE - File #4 MACH START - 0
              XIC - File #3 CONDITION - 8
              File #4 MACH START - 3
              File #5 REAR FLAP - 0
              File #6 MAJOR FLAP - 0
              File #7 INDEXING - 0
              File #8 BOX JAM - 0
              XIO - File #7 INDEXING - 3
T4:0        - MACHINE BOX JAM AT INFEED TIME DELAY
              TON - File #8 BOX JAM - 1
T4:0/DN     - XIC - File #8 BOX JAM - 1, 3
T4:0/EN     - XIC - File #8 BOX JAM - 1
T4:1        - REAR FLAP FOLDERS EXTEND TIME DELAY
              TON - File #5 REAR FLAP - 2
T4:1/DN     - XIC - File #5 REAR FLAP - 3, 4
              XIO - File #5 REAR FLAP - 1, 2
T4:1/EN     - XIC - File #5 REAR FLAP - 2
T4:2        - REAR FLAP FOLDERS RESET TIME DELAY
              TON - File #5 REAR FLAP - 3
T4:2/DN     - XIO - File #5 REAR FLAP - 3, 4
T4:2/EN     - XIC - File #5 REAR FLAP - 3
T4:3        - MAJOR FLAP FOLDER EXTEND TIME DELAY
              TON - File #6 MAJOR FLAP - 1
T4:3/DN     - XIC - File #6 MAJOR FLAP - 3
              XIO - File #6 MAJOR FLAP - 1
T4:3/EN     - XIC - File #6 MAJOR FLAP - 1
T4:4        - MAJOR FLAP FOLDER RESET TIME DELAY
              TON - File #6 MAJOR FLAP - 2
T4:4/DN     - XIO - File #6 MAJOR FLAP - 2, 3
              File #7 INDEXING - 1
T4:4/EN     - XIC - File #6 MAJOR FLAP - 2
T4:5        - INFEED PHOTO ELECTRIC TIME DELAY
              TON - File #5 REAR FLAP - 1
T4:5/DN     - XIC - File #5 REAR FLAP - 2
T4:5/EN     - XIC - File #5 REAR FLAP - 1
T4:6        - INFEED INDEXING GATE EXTEND TIME DELAY
              TON - File #7 INDEXING - 1
T4:6/DN     - XIC - File #7 INDEXING - 3
T4:6/EN     - XIC - File #7 INDEXING - 1
T4:8        - BOX JAM RELAY RESET TIMER
              TON - File #8 BOX JAM - 3
T4:8/DN     - XIO - File #8 BOX JAM - 3
T4:10       - ENERGY SAVING MODE TIME DELAY
              TON - File #4 MACH START - 3
T4:10/DN    - XIC - File #8 BOX JAM - 3
C5:0        - TOP LOW TAPE BOX COUNTER TILL INFEED GATE RAISES
              CTU - File #9 LOW TAPE - 1
              RES - File #9 LOW TAPE - 3
C5:0/DN     - XIC - File #7 INDEXING - 3
C5:1        - BOTTOM LOW TAPE BOX COUNTER TILL INFEED GATE RAISES
              CTU - File #9 LOW TAPE - 2
              RES - File #9 LOW TAPE - 4
C5:1/DN     - XIC - File #7 INDEXING - 3
U:3         - JSR - File #2 MAIN_PROG - 0
U:4         - JSR - File #2 MAIN_PROG - 1
U:5         - JSR - File #2 MAIN_PROG - 2
U:6         - JSR - File #2 MAIN_PROG - 3
U:7         - JSR - File #2 MAIN_PROG - 4
U:8         - JSR - File #2 MAIN_PROG - 5
U:9         - JSR - File #2 MAIN_PROG - 6

```